

JB/JC

Operative Manual



INDEX

INSTALLATION WARNINGS	3
1. TECHNICAL FEATURES OF THE JUNCTION CARDS	3
2. ANALOGIC LOAD CELL.....	4
2.1 LOAD CELL CONNECTION.....	4
2.2 CONNECTION TO INDICATOR	5
2.3 SERIES CONNECTION WITH 2 OR MORE BOARDS	6
3. DIGITAL JUCTION BOARD.....	7
3.1 6 WIRES LOAD CELL CONNECTION	7
FULL DUPLEX.....	7
3.2 4 WIRES LOAD CELL CONNECTION	7
3.3 RCPTD LOAD CELLS CONNECTIONS	8
3.3 CONNECTION TO INDICATOR	9
3.4 SERIES CONNECTION WITH 2 OR MORE BOARDS	10
3.6 TERMINATION JUMPER	11
4. EQUALISATION PROCEDURE.....	12

INSTALLATION WARNINGS

A flat and levelled laying surface.

Stability and absence of vibrations.

No dust or strong vapours.

Levelled platforms or even laying surface of the load cells.

Moderate temperature and humidity (15-30° C and 40-70%).

Make sure about correct earthing.

Avoid welding of load cells installed.

Use waterproof connections and sheaths to protect the load cell cables.

Use waterproof junctions boxes to connect the cells.

Everything not expressly described in this manual has to be considered as improper use of the equipment.

Tighten well the unused holes by means of caps.

Connect the junction boxes to the grounding point with a short cable with a minimum cross section of 50mm².

1. TECHNICAL FEATURES OF THE JUNCTION CARDS

Maximum input voltage: 24Vdc.

Maximum input current. 700mA

Maximum input load cell signal: 1000mV

Temperature effect: 50ppm/°C

The 10 load cell version is fitted with Surge Arresters, against overcurrent and over tension.

2. ANALOGIC LOAD CELL

2.1 LOAD CELL CONNECTION

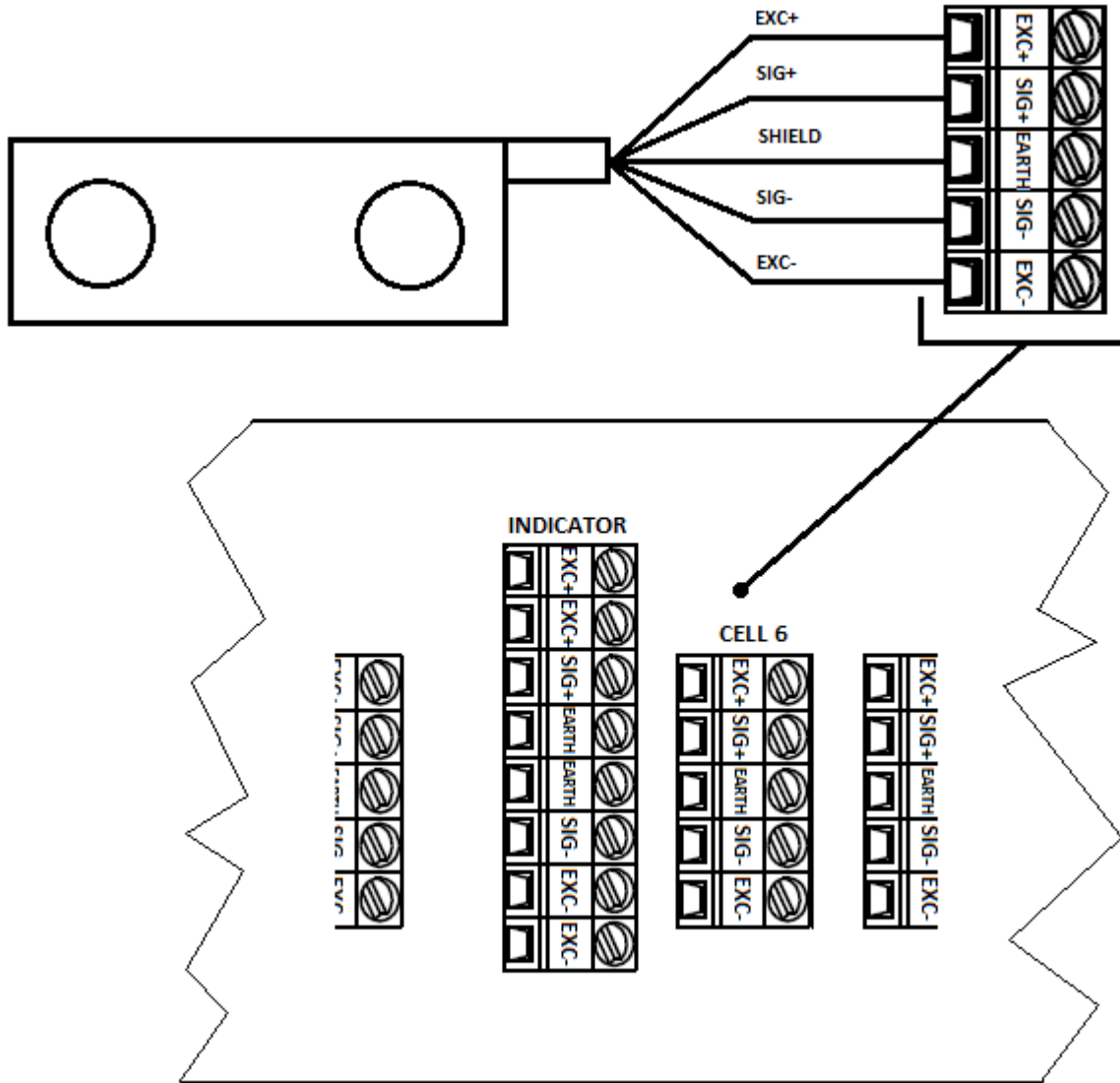

Note: with 6 cables load cells, SENSE+ must be short-circuited with EXC+, and SENSE- must be short-circuited with EXC- .

2.2 CONNECTION TO INDICATOR

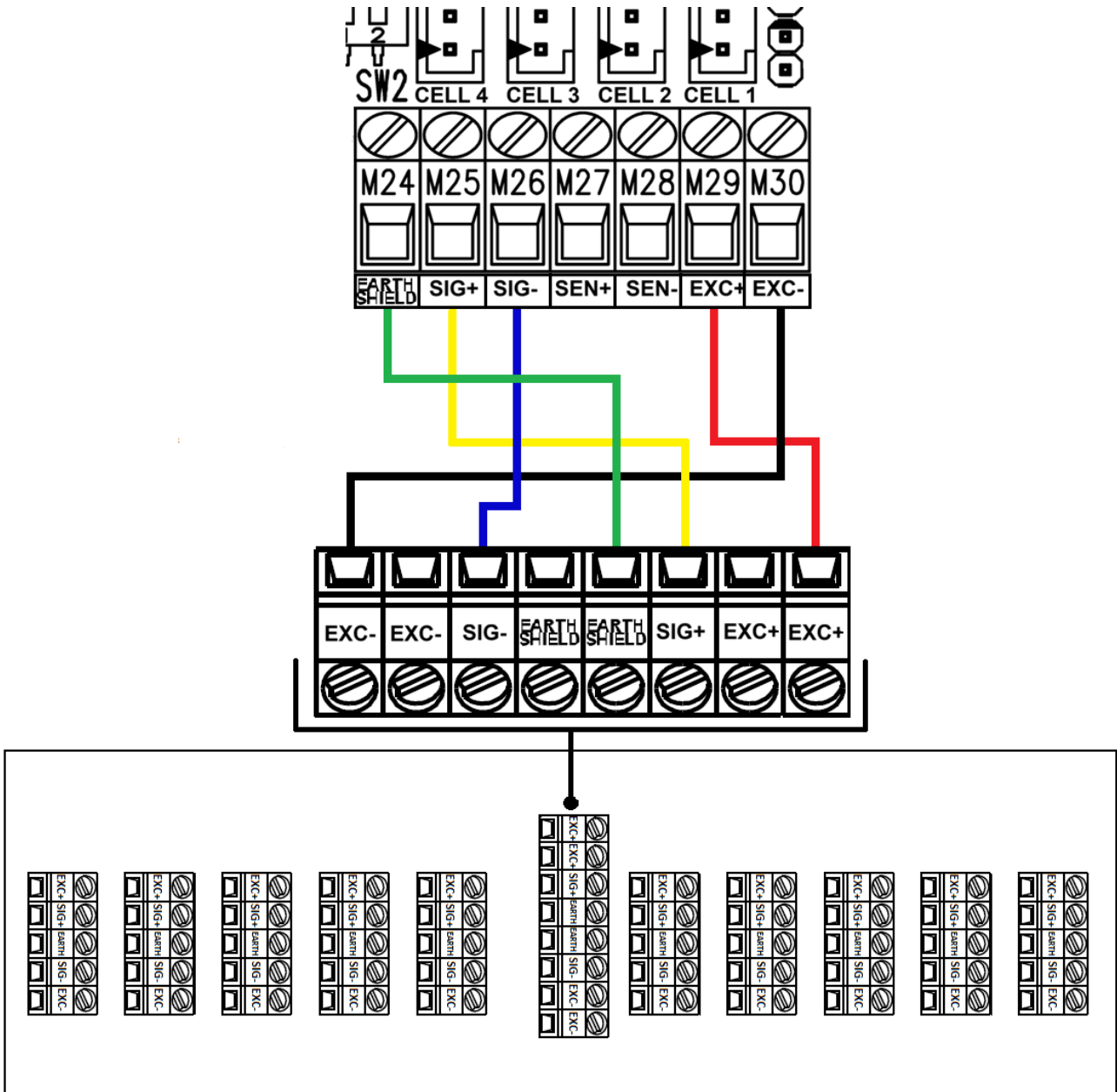

2.3 SERIES CONNECTION WITH 2 OR MORE BOARDS

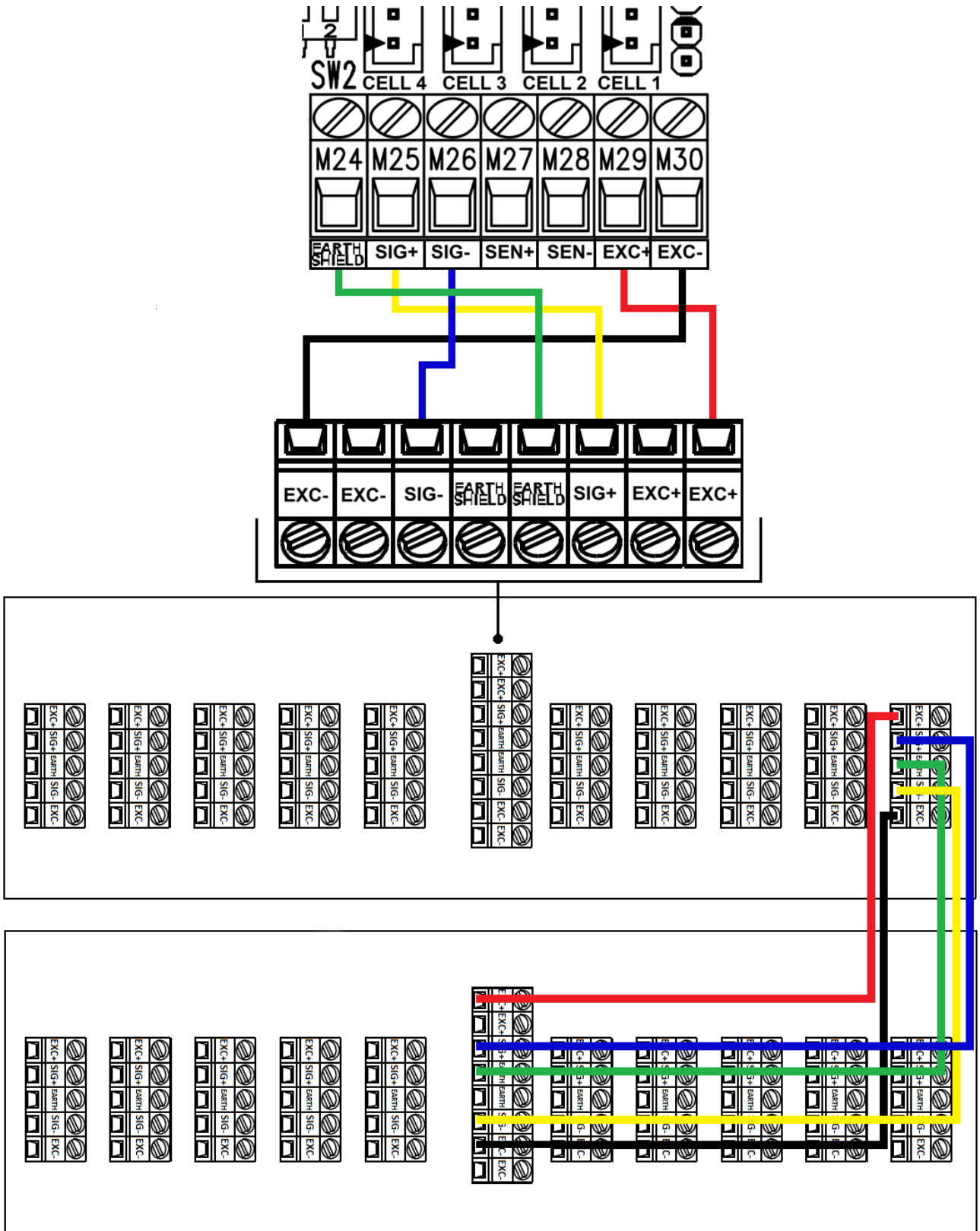

3. DIGITAL JUNCTION BOARD

Connect the load cells in order starting from terminal CELL1 (CELL1, CELL2, CELL3, ...)

3.1 6 WIRES LOAD CELL CONNECTION

HALF DUPLEX

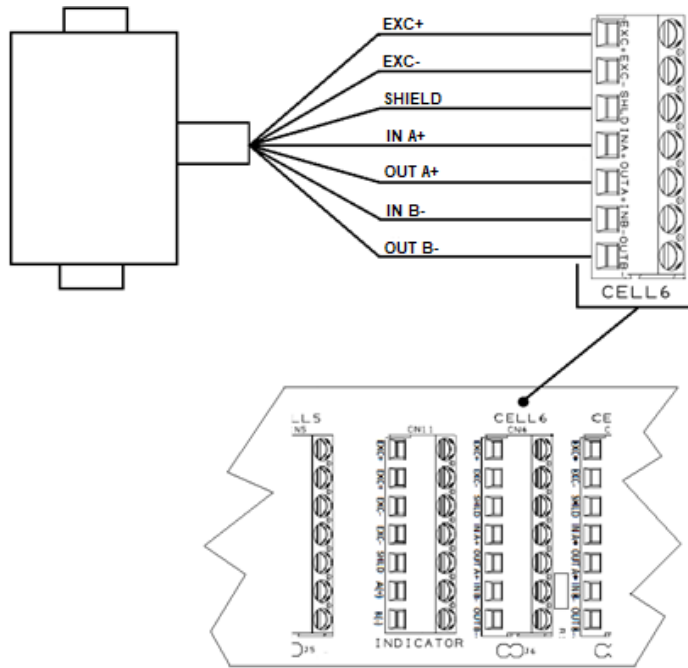

3.2 4 WIRES LOAD CELL CONNECTION

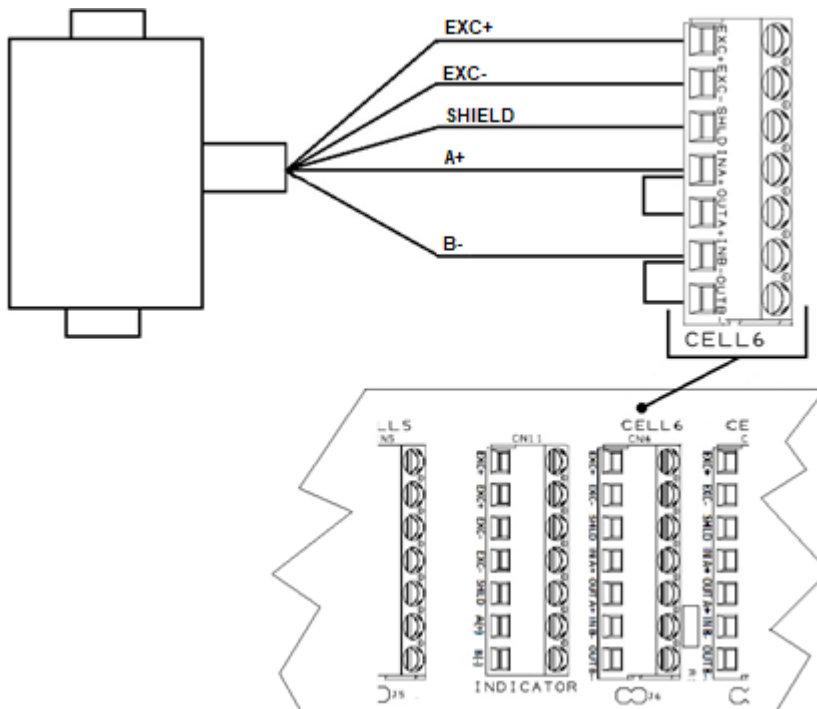

3.3 RCPTD LOAD CELLS CONNECTIONS

For the connection of the cable of the load cells on the board, follow the instruction of the previous paragraph.

For the proper functioning of these load cells, both the dip switches must be set to OFF (see below):

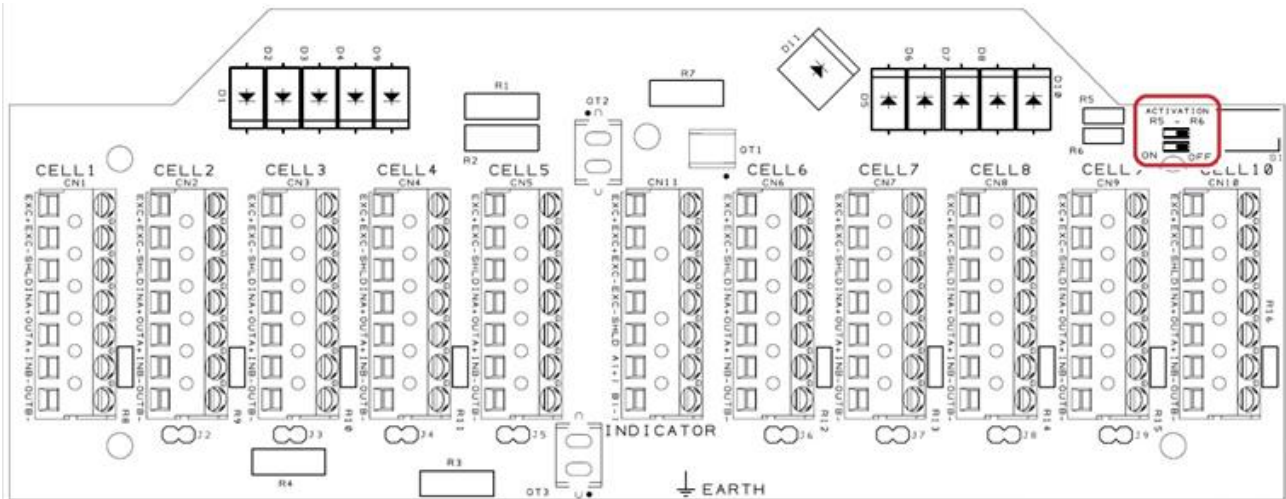

3.3 CONNECTION TO INDICATOR

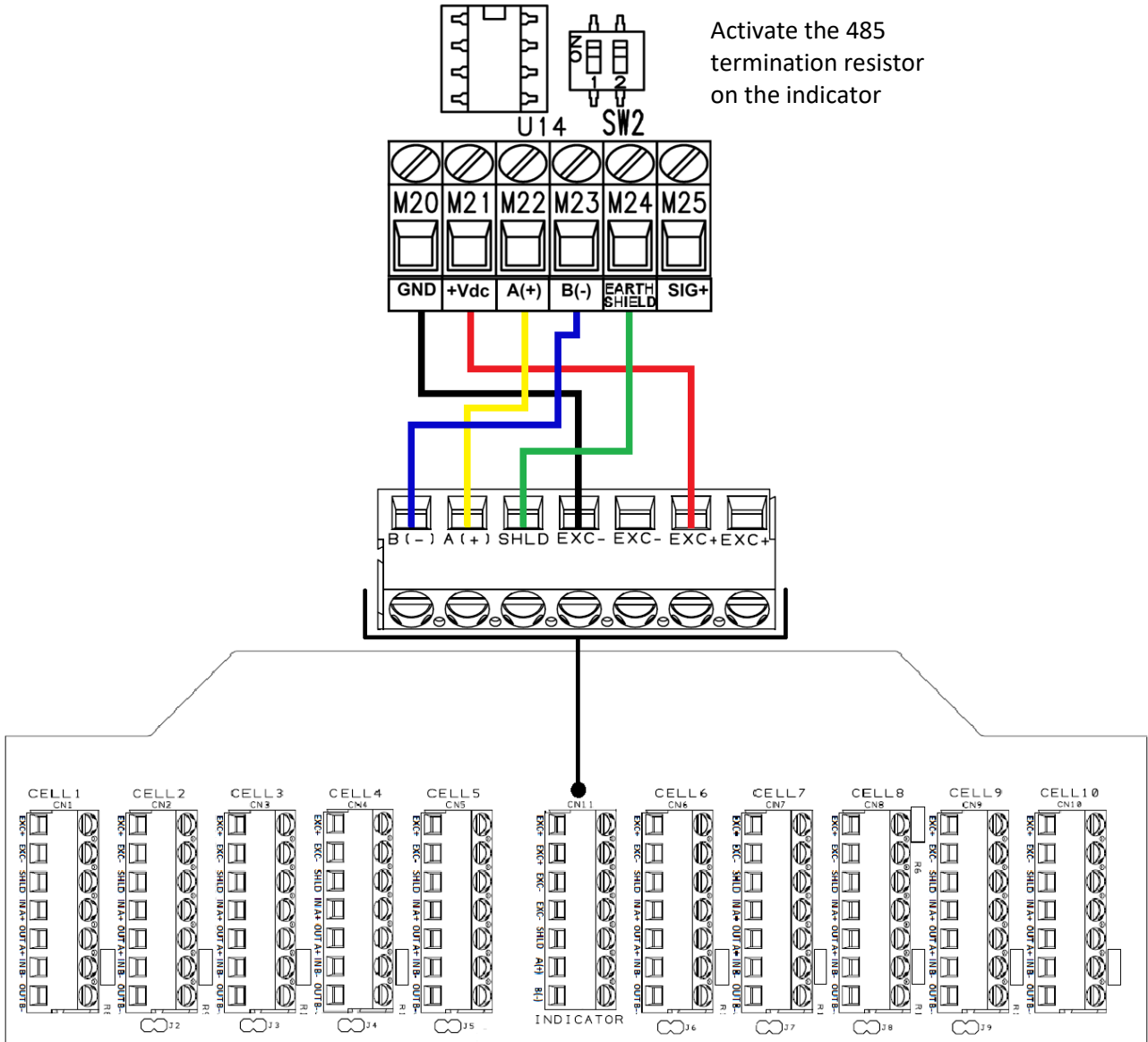

3.4 SERIES CONNECTION WITH 2 OR MORE BOARDS

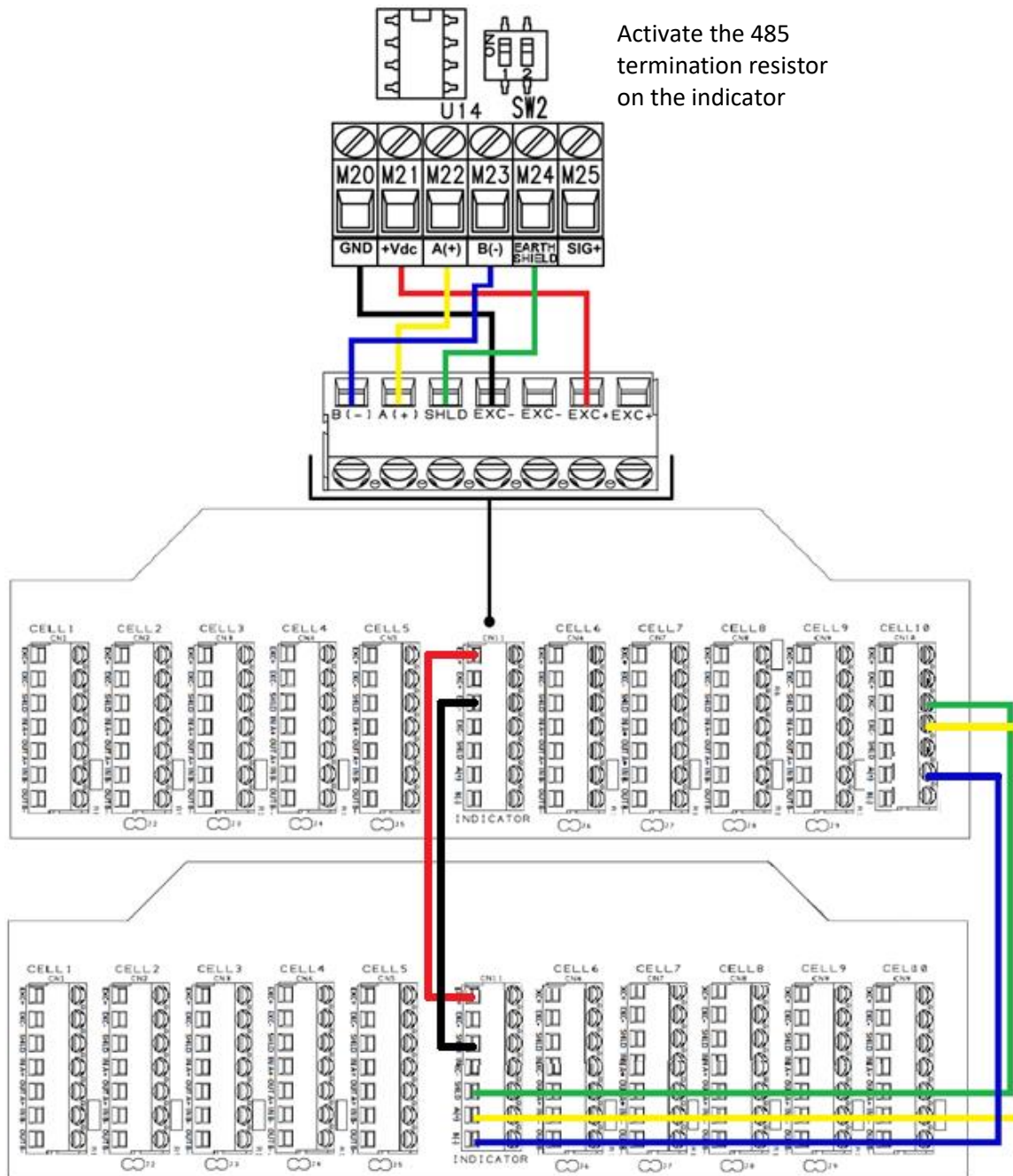

The first board must have all termination jumpers open (including S1).

Cell terminal 10 is not used for connecting the cell, but for connecting the second board. Only use pins 4 and 6 in terminal CELL10.

The second board must have the termination jumper closed on the last connected cell.

The indicator must have the 485 line termination resistor active.

3.6 TERMINATION JUMPER

According to the number of connected load cells, it is necessary to close one of the jumpers which are on the board

If the number of installed load cells is 10, there are no jumpers to close.

If the number of the installed load cells varies from 2 to 9, the jumper to close is always the one corresponding to the last cell (in numerical order).

Example:

if there are 8 load cells, the jumper to be closed is J8.

On the other side of the line (weight indicator) it is necessary to activate with the dip switch the 120 Ohm termination resistance between A(+) and B(-) clamps.

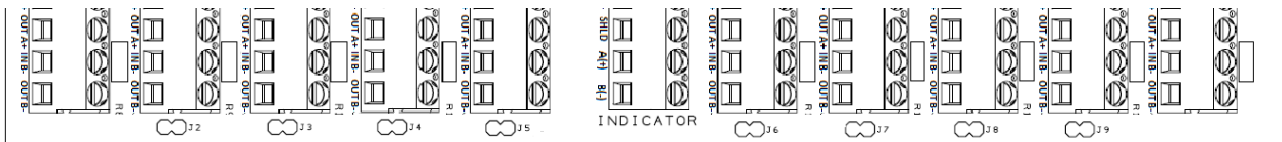

4. EQUALISATION PROCEDURE

1. Tighten all trimmer screws, in clockwise orientation.
2. Carry out the calibration with a standard weight of about $1 / (n - 1)$ of the capacity (where n is the number of the cells). Position it centrally.
3. Put the standard weight near to the points corresponding to the load cells. Identify the cell with the lowest visualized weight.
4. Adjust the remaining cells in order to have on all of them a weight equal to the cell with the lowest signal. Follow these steps:
 - A. Position the standard weight on the point corresponding to the cell with the highest weight.
 - B. Loosen (anticlockwise orientation) the cell trimmer's bolt until the weight is equal to the one of the cell with the lowest value.
 - C. Repeat steps "A" and "B" for the remaining points related to the cells.
5. Check again that each point corresponding to the cells has the same weight. If so, carry out the calibration again, by positioning the standard weight centrally. Otherwise, repeat the points 3 and 4.

N.B. For a good equalisation of the system, it is advisable to use a high resolution visualization and a compact standard weight, with a laying surface reduced as much as possible.