

# UL Control Drawing



NON-HAZARDOUS LOCATION or  
HAZARDOUS LOCATION

Class I, Division 1, Groups A, B, C, D  
Class II, Division 1, Groups E, F, G  
Class III, Division 1 or  
Class I, Zone 0 and 1, IIC  
Zone 20 and 21, IIIC

NON-HAZARDOUS LOCATION or  
HAZARDOUS LOCATION

Class I, Division 2, Groups A, B, C, D or  
Class I, Zone 2, IIC

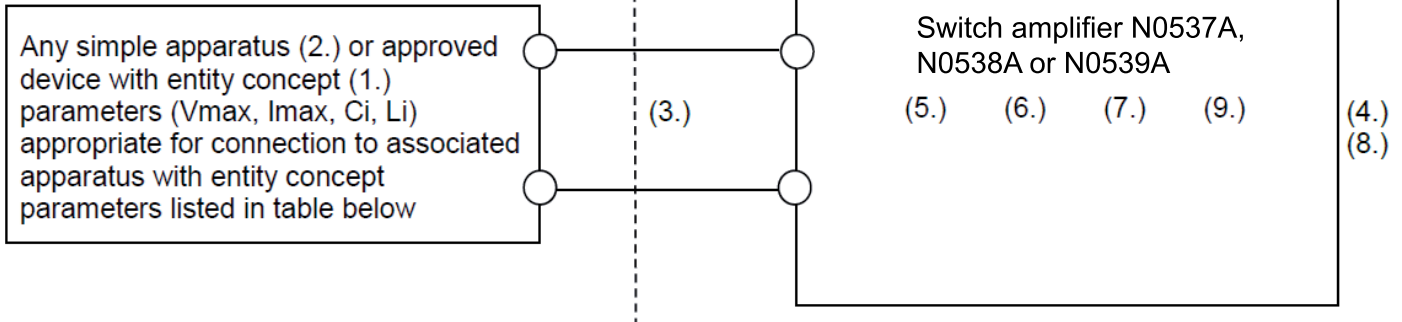

## NOTES:

1) The Entity Concept allows interconnection of intrinsically safe apparatus with associated apparatus not specifically examined in combination as a system when the approved values of  $V_{oc}$  (or  $U_o$ ) and  $I_{sc}$  (or  $I_o$ ) for the associated apparatus are less than or equal to  $V_{max}$  ( $U_i$ ) and  $I_{max}$  ( $I_i$ ) for the intrinsically safe apparatus and the approved values of  $C_a$  ( $C_o$ ) and  $L_a$  ( $L_o$ ) for the associated apparatus are greater than  $C_i + C_{cable}$  and  $L_i + L_{cable}$ , respectively, for the intrinsically safe apparatus,  
Where  $C_{cable} = 60pF/ft$  if unknown  
Where  $L_{cable} = 0.20uH/ft$  if unknown

2) Simple apparatus: an electrical component or combination of components of simple construction with well-defined electrical parameters that does not generate more than 1.5 V, 100 mA, 25 mW, or is a passive component that does not dissipate more than 1.3 W and is compatible with the intrinsic safety of the circuit in which it is used.

3) Wiring methods must be in accordance with all applicable installation requirements of the county in use. For US, this is NFPA 70 (NEC) article 504 with additional information in ANSI-ISA –RP12.06.01. For Canada this is CSA 22.1-12 (CEC) section 18 and appendix F.

4) Barriers shall not be connected to any device which uses or generates internally any voltage in excess of 253 V r.m.s. unless the device has been determined to adequately isolate the voltage from the barrier.

5) The barriers are rated 'non-incendive' for use in Class I, Division 2 or Zone 2 or non-hazardous location. A temperature rating of T4 applies to all non-incendive rated barriers.

6) If the barriers are intended to be mounted in a Division 2 location, they shall be mounted within a tool-secured enclosure which is capable of accepting one or more of the Class I, Division 2 wiring methods specified in the National Electrical Code (ANSI/NFPA 70) or Canadian Electrical Code (C22.1), as applicable. The equipment shall be installed in an enclosure with a minimum ingress protection of IP2X.

7) If the barrier are intended to be mounted in a Zone 2 location, they shall be mounted within a tool-secured enclosure which is capable of accepting one or more of the Class I, Zone 2 wiring methods specified in the National Electrical Code (ANSI/NFPA 70) or Canadian Electrical Code (C22.1), as applicable. The equipment shall be installed in an AEx and EX certified IP54 enclosure unless the apparatus is intended to be afforded an equivalent degree of protection by location. The device can only be used in an area of not more than Pollution degree 2.

## Entity Parameters

Model Number	Terminals	V <sub>OC</sub> (U <sub>0</sub> ) (V)	I <sub>SC</sub> (I <sub>0</sub> ) (mA)	P <sub>0</sub> (mW)	Groups	C <sub>a</sub> (C <sub>0</sub> ) [μF]	L <sub>a</sub> (L <sub>0</sub> ) [mH]	L <sub>0</sub> / R <sub>0</sub> [μH / Ω]
N0537A N0538A N0539A	1, 2, 3; 4, 5, 6	10.5	17.1	45	A,B IIC	2.41	121.5	792
					C,E,F,G IIB, IIIC	16.8	486.3	3167
					D IIA	75	972.7	6334

The values of L<sub>0</sub> and C<sub>0</sub> listed in the table above are allowed if one of the following conditions is met:

- the total L<sub>i</sub> of the external circuit (excluding the cable) is < 1% of the L<sub>0</sub> value or
- the total C<sub>i</sub> of the external circuit (excluding the cable) is < 1% of the C<sub>0</sub> value.

The values of L<sub>0</sub> and C<sub>0</sub> listed in the table above shall be reduced to 50% when both of the following conditions are met:

- the total L<sub>i</sub> of the external circuit (excluding the cable) is > 1% of the L<sub>0</sub> value and
- the total C<sub>i</sub> of the external circuit (excluding the cable) is > 1% of the C<sub>0</sub> value.

**Note:** the reduced capacitance of the external circuit (including cable) shall not be greater than 1μF for IIA, IIB and 600nF for IIC.

### WARNING:

- Substitution of components may impair intrinsic safety and suitability for use in Class I, Div. 2 / Zone 2.
- Do not disconnect the equipment or actuate switches when the equipment is energized and an explosive atmosphere is present.

### AVERTISSEMENT:

- La substitution de composants peut compromettre la sécurité intrinsèque et l'adéquation à une utilisation en Classe I, Div. 2 / Zone 2.
- Ne pas débrancher l'équipement et ne pas actionner les commutateurs lorsque l'équipement est sous tension et exposé à une atmosphère explosive.