

# PC6 single point load cell

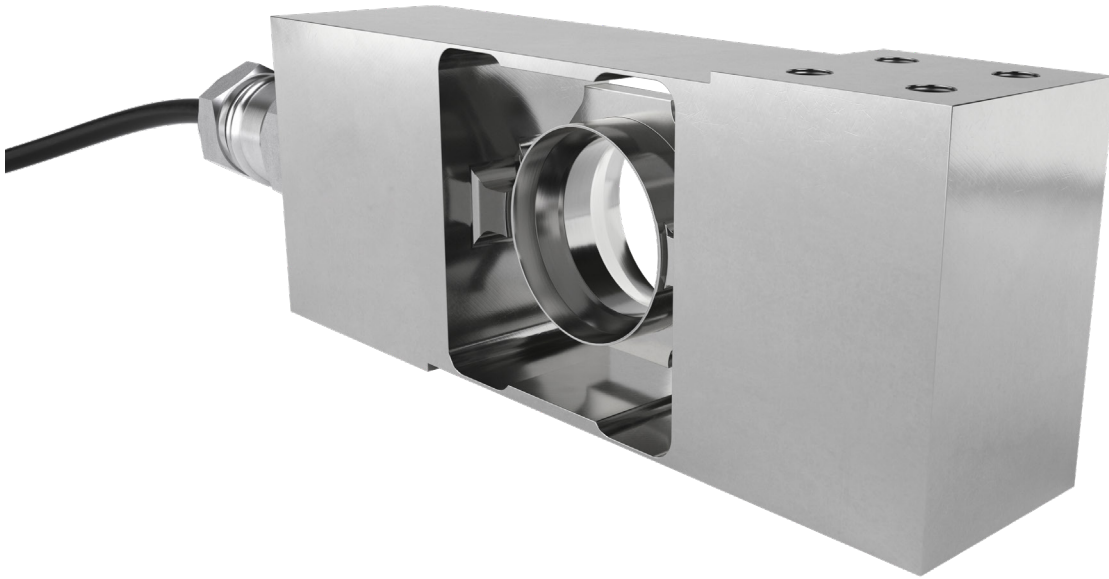

## product description

Designed for high accuracy trade approved weighing in wet environments, the PC6 single point load cell is the benchmark product. From capacities as low as 10kg and accuracy classes including OIML 4000d, the PC6 is ideal for weighing machinery in food and beverage applications that demand accuracy and robustness. The compact nature of the PC6 lends itself also to the construction of high accuracy bench scales and multi-head weighers.

## applications

Bench scales, small platform scales, multi-head weighers, high speed checkweighers.

## approvals

OIML approval to C3 (Y = 12,500), C3 MI6 (Y = 12,500) and C4 (Y = 12,500)

NTEP approval to 5,000 intervals, Class III

ATEX hazardous area approval for zones 0, 1, 2, 20, 21 and 22

FM hazardous area approval

## accessories + options

Compatible range of electronics

Y = 25,000 for C3, C3 MI6 and C4

## key features

Stainless steel construction

Hermetically sealed to IP68

Wide capacity range from 10kg to 200kg

For platform sizes of up to 600mm x 600mm

High accuracy

High input resistance

Integral mounting spacer



RoHS  
compliant



 **flintec**  
quality + precision

## specifications

Maximum capacity ( $E_{max}$ )	kg	10 / 20 / 50 / 100 / 200			
Accuracy class according to OIML R60		(GP)	C3	C3 MI 6	C4
Maximum number of verification intervals ( $n_{LC}$ )		n.a.	3,000		4,000
Minimum load cell verification interval ( $v_{min}$ )		n.a.	$E_{max} / 12,500$		
Temperature effect on minimum dead load output ( $TC_0$ )	%*RO/10°C	± 0.0400	± 0.0112		
Temperature effect on sensitivity ( $TC_{RO}$ )	%*RO/10°C	± 0.0200	± 0.0100		± 0.0080
Combined error	%*RO	± 0.0500	± 0.0200	± 0.0180	± 0.0180
Non-linearity	%*RO	± 0.0400	± 0.0166	± 0.0166	± 0.0125
Hysteresis	%*RO	± 0.0400	± 0.0166	± 0.0083	± 0.0125
Creep error (30 minutes) / DR	%*RO	± 0.0600	± 0.0166	± 0.0083	± 0.0125
Optional: Min. load cell verification interval ( $v_{min opt}$ )		n.a.	$E_{max} / 25,000$		
Optional: Temp. effect on min. dead load output ( $TC_0 opt$ )	%*RO/10°C	n.a.	± 0.0056		
Rated Output (RO)	mV/V	2 ± 5%			
Zero balance	%*RO	± 5			
Excitation voltage	V	5...15			
Input resistance ( $R_{LC}$ )	Ω	1,100 ± 50			
Output resistance ( $R_{out}$ )	Ω	960 ± 50			
Insulation resistance (100 V DC)	MΩ	≥ 5,000			
Safe load limit ( $E_{lim}$ )	%* $E_{max}$	200			
Ultimate load	%* $E_{max}$	300			
Safe side load	%* $E_{max}$	100			
Maximum platform size; loading acc. to OIML R76	mm	350 x 350 for 10...20 kg / 500 x 500 for 50 kg / 600 x 600 for 100...200 kg			
Maximum off centre distance at maximum capacity	mm	115 for 10...20 kg / 166 for 50 kg / 200 for 100...200 kg			
Compensated temperature range	°C	-10...+40			
Operating temperature range	°C	-40...+80 (ATEX -40...+60)			
Load cell material		stainless steel 17-4 PH (1.4548)			
Sealing		complete hermetic sealing; cable entry sealed by glass to metal header			
Protection according EN 60 529		IP68 (up to 2 m water depth) / IP69K			
Packet weight	kg	1.32			

The limits for Non-Linearity, Hysteresis, and  $TC_{RO}$  are typical values.

The sum of Non-linearity, Hysteresis and  $TC_{RO}$  meets the requirements according to OIML R60 with  $p_{LC}=0.7$ .

## product dimensions (mm)

10kg, 100kg and 200kg

20kg and 50kg

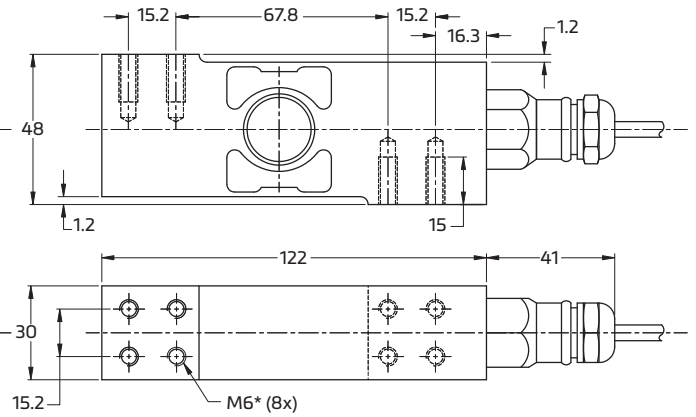
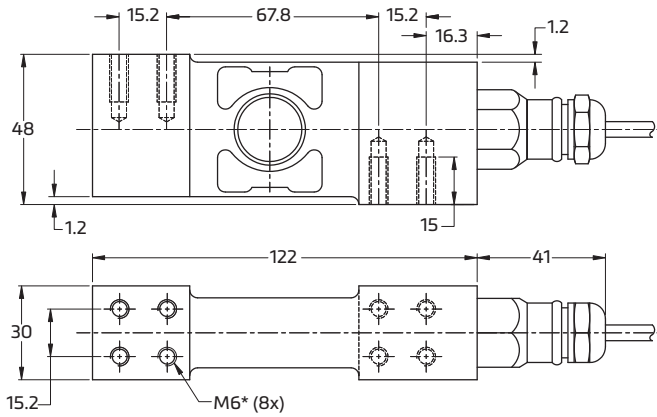
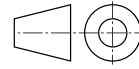

Mounting bolts M6 8.8; torque 10 Nm. Torque value assumes oiled threads.

\* Unified thread 1/4-20 UNC is available.

\*\* As it has in no way influence on the functionality and accuracy of the load cell, this dimension might be in singular cases shorter.

## wiring

The load cell is provided with a shielded, 6 conductor cable (AWG 26) or with a shielded, 4 conductor cable (AWG 24).

Cable jacket: polyurethane.

Cable length: 3 m

Cable diameter: 5 mm

The shield is floating or connected to the load cell body

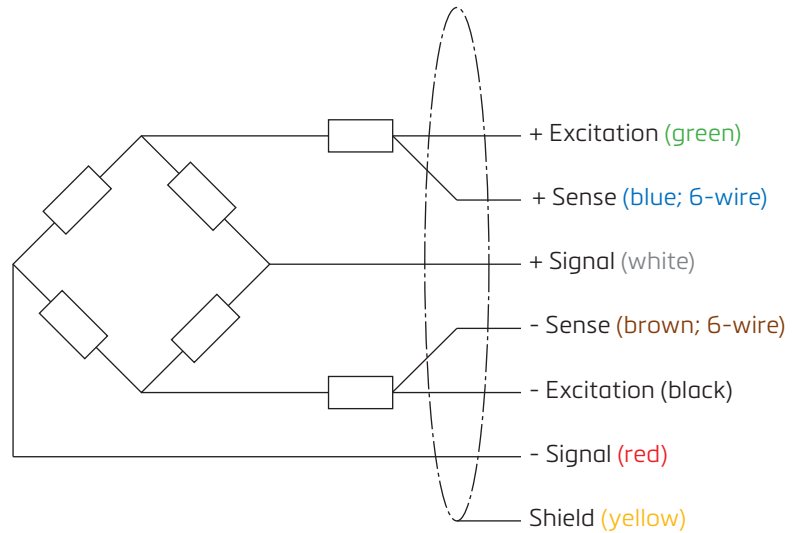

Specifications and dimensions are subject to change without notice.