

## Operating Instructions

Original Operating Instructions

# Sartorius PMA.Power

Model PMA35001-Y

Electronic Paint-mixing Scale for Use Hazardous Areas

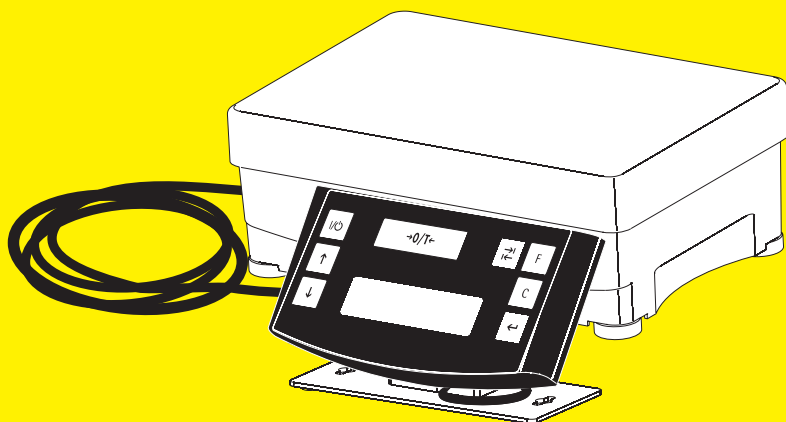

1000025284



# SARTORIUS

# General View of PMA35001-Y (PMA.Power)

For Use in Zone 2 Hazardous Areas

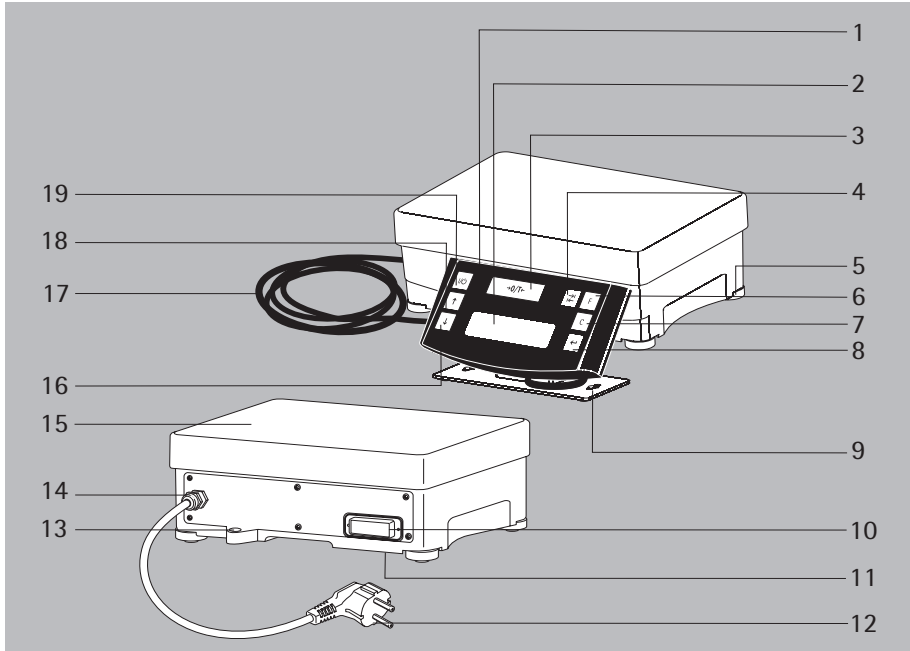

- 1 Display and control unit
- 2 Display
- 3 Zero/tare key
- 4 Toggle key depending on the menu setting:  
You can configure the PMA35001-Y menu to enable toggling between grams (g) and parts per pound (p)
- 5 Leveling foot
- 6 Factor key for paint-mixing applications
- 7 [Clear] key and [REC] key for paint-mixing applications
- 8 [ENTER] key and [MEM] key for paint-mixing applications
- 9 Mounting bracket for display and control unit
- 10 Interface (25-contact D-Sub socket)
- 11 Grounding terminal
- 12 Power cord with plug
- 13 Level indicator

- 14 Cable connection
- 15 Load plate
- 16 'Down' key
- 17 Power supply and data cable for the display and control unit
- 18 'Up' key
- 19 On/Off (standby) key

## Symbols

The following symbols are used in these instructions:

- Indicates a required action
  - Describes what happens after you have performed a particular action
1. Perform actions in the specified order
  2.
    - Indicates an item in a list
- Indicates a hazard

---

## Contents

General View of PMA35001-Y (PMA.Power) .....	2
Intended Use .....	3
Warnings and Safety Precautions .....	3
Getting Started .....	6
Operation .....	9
Applications .....	10
Calibration/Adjustment .....	13
Menu Settings .....	14
Troubleshooting Guide .....	19
Care and Maintenance .....	20
Disposal .....	21
Interface Description .....	22
Technical Data .....	23
Accessories .....	24
Documents .....	25

## Intended Use

The PMA35001-Y (PMA.Power series) scale is specially designed for use in paint-mixing applications. This scale can be operated via the keypad in stand-alone operation or using application software (such as a paint-mixing program from a paint manufacturer) installed on a connected PC.

If you wish to create your own application software, Sartorius can supply the required drivers for DOS or Windows operating systems.

### Note:

- Make sure that you read the warnings and safety precautions carefully before installing and operating your PMA35001-Y scale.

## Warnings and Safety Precautions

### Note:

Improper use or handling can result in damage and/or injury. The scale should only be installed and operated by qualified personnel. When operating the equipment in a Zone 2 hazardous area, make sure you observe the warnings and safety precautions in their entirety during installation and operation, as well as while performing maintenance and repair work on the equipment. All relevant standards, regulations, occupational safety requirements and environmental protection laws valid in your country must be observed. Please ask your supplier regarding the regulations applicable in your country. It is important that all personnel using the equipment understand this warning and safety information and have access to all relevant documents at all times. Furthermore, the warning and safety information supplied with any electrical equipment, such as peripheral devices, must be observed as well. These warnings and safety precautions must be supplemented by the operator as required. All operating personnel must be informed of any additions to these instructions. Make sure the equipment is accessible at all times.

### General Provisions for Installing the PMA35001-Y

PMA35001-Y models meet the requirements defined in EC Directive 2014/34/EU for Class II, Category 3G equipment. The safety instructions listed in drawing 2444395 (refer to Documents) must be strictly observed.

- 
- PMA35001-Y models meet the requirements of the EC Directives for electromagnetic compatibility and electrical safety (see EC Declaration of Conformity under "Documents" on page 25).  
The area of use for the PMA35001-Y is defined in the included documentation. All restrictions listed in the included documentation must be observed.
  - Operating the PMA35001-Y beyond the restrictions indicated is not permitted, and is considered use of the equipment for other than its intended purpose. Any installation work that does not conform to the instructions in this manual results in forfeiture of all claims under the manufacturer's warranty.
  - If the equipment is modified by anyone other than persons authorized by Sartorius, authorization is withdrawn and all claims under the manufacturer's warranty are forfeited.
  - The installation of the PMA35001-Y in a hazardous area must be carried out by a certified electrician.  
A certified electrician is someone who is familiar with the assembly, start-up and operation of the system.  
He is also familiar with all relevant guidelines and regulations, and has the required qualifications for performing the installation. If you need assistance, contact your Sartorius dealer or the Sartorius Service.
  - Connect all equipment, including peripheral devices, to the equipotential bonding conductor.
  - The display values can be impacted when subjected to extreme electromagnetic influence.  
When the negative influence has subsided, the scale will again be fully operational.
  - The equipment must only be used indoors.
  - Make absolutely sure to disconnect the scale from power (unplug the power cord) before you connect or disconnect a peripheral device (printer or PC) to or from the interface port.
  - If you use cables purchased from another manufacturer, check the pin assignments in the cable against those specified by Sartorius before connecting the cable to Sartorius equipment, and disconnect any wires that are assigned differently. The operator shall be solely responsible for any damage or injuries that occur when using cables not supplied by Sartorius.
  - The power connection must be made in accordance with the regulations applicable in your country. If you need assistance, contact your Sartorius dealer or the Sartorius Service. Any installation work that does not conform to the instructions in this manual results in forfeiture of all claims under the manufacturer's warranty.
  - To avoid generating static electricity when using the dust cover:  
The cover should only be cleaned using a moist cloth.

---

### **For the User**

- Always make sure the equipment is disconnected from AC power before performing any installation, cleaning, maintenance or repair work on the scale.
- If you see any indication that the scale cannot be operated safely (for example, due to damage), disconnect the scale from AC power and prevent use of the equipment for the time being.
- Chemicals (e.g. gases or liquids) that can corrode and damage the inside or outside of the device must be kept away from the equipment.  
Handle the equipment and any accessories in accordance with the IP rating (IEC/EN 60529).
- The casing on all connecting cables, as well as the casing on wires inside the equipment housing, is made of PVC or rubber.
- The permitted ambient temperature range during operation is 0°C to +40°C.  
Make sure that the equipment is properly ventilated to prevent the buildup of excessive heat.
- Only use original Sartorius spare parts.
- Do not close a paint can using a hammer while it is still on the load plate!  
This will damage the weighing system!

# Getting Started

## Scope of delivery

- Scale
- Load plate
- USB | RS232 data cable



## Installation site

Choose a suitable installation site where the device will not be exposed to drafts, heat radiation, moisture or vibrations.

Read the Operating Instructions before connecting the device to the mains power supply.

⚠ Observe the safety instructions.

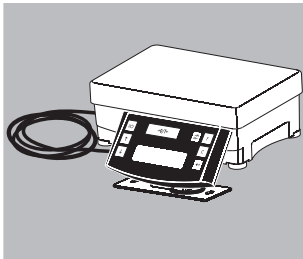

- ▶ Unpack the scale carefully.
- ▶ After unpacking the equipment, inspect the device immediately for any visible damage that may have been caused by rough handling during shipment.

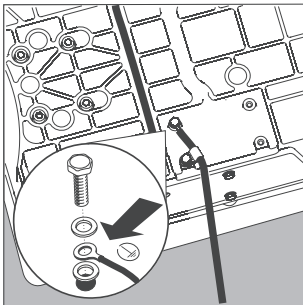

## ⚠ Caution

The scale must be grounded before installing the device in a Zone 2 hazardous area. Root the grounding wire (cross section 4mm<sup>2</sup> in minimum) through the eyelet. Connect the cable to the grounding terminal (11); see illustration.

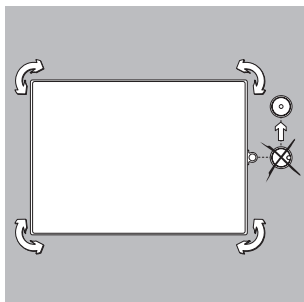

## Level the weighing platform

Purpose:

- To compensate for uneven areas at the place of installation
- To ensure that the equipment is placed in a perfectly horizontal position for consistently reproducible weighing results.

Always level the weighing platform again any time after it has been moved to a different location.

- ▶ Check to ensure that all leveling feet rest securely on the work surface.
- ▷ Each of the leveling feet must support an equal load!
- ▶ Adjusting the leveling feet: To raise the weighing platform, extend the leveling feet (turn counterclockwise). To lower the weighing platform, retract the leveling feet (turn clockwise).
- ▶ Level the weighing platform using the four leveling feet. Turn the feet until the air bubble is centered in the level indicator.

- ▶ Place the load plate on the scale.

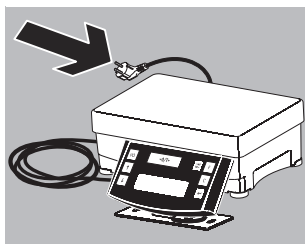
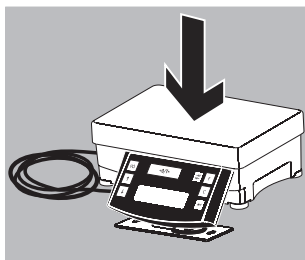

## Connecting to AC Power

The equipment is powered through the scale's power cord. Make sure that the voltage rating printed on this unit is identical to your local line voltage.

If the stated supply voltage or the plug design of the power cord does not comply with the standard you use, please inform your nearest Sartorius representative or your supplier.

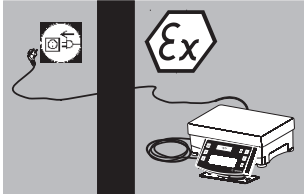

### Installation

The device must be plugged into a properly installed wall outlet which has a protective grounding conductor (PE) and a max. (16A) fuse.

- ▶ Connection of the power cord plug (12) outside of the hazardous area or mechanically secured (refer to "Safety Information" documents).
- ▶ Plug the power cord into a wall outlet (mains). Observe all warnings and safety precautions.
- ⚠ See also: "Safety Instructions" documents. Install the scale in such a way or protect the power cord in such a way that mechanical tensile load on the plug and cable gland (on the scale) is prevented!

### Note:

When installing the scale in a Zone 2 hazardous area, connectors may only be plugged in or disconnected in a currentless/dead-voltage state.

Disconnect the scale from the power line before connecting peripheral devices (printer, PC) to the data interface of the device.

- ⚠ Observe all warnings and safety precautions. See also: "Safety Instructions" documents.
- ▶ When connecting peripheral devices (printer, PC) to the scale's data interface, make sure that the screws on the data plug are tightened securely.

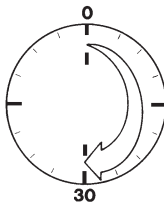
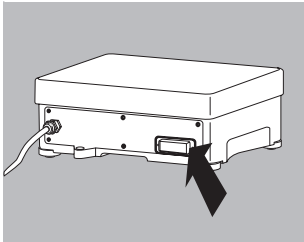

Always allow approximately 30 minutes for the scale to warm up after connecting it to the power supply and before adjustment.

# Operation

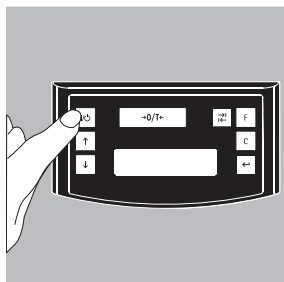

Press the  key (19) to turn on the scale.

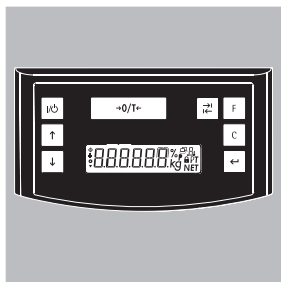

Once the scale has been turned on, it will run an automatic self-test. This is concluded with the readout **0.0 g**.

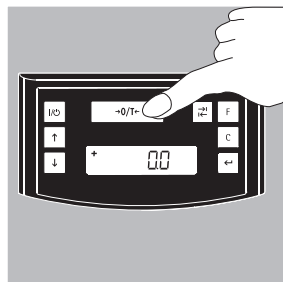

If a different value is displayed: Tare the scale using the  key (Zero/tare) (3).

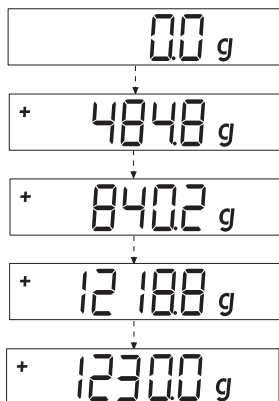

## Weighing with One Decimal Place

Place an empty paint can on the load plate.

Press the  key (Zero/tare) (3).

The display shows »0.0 g«. Pour the first component of your formula into the can and read off the weight when the stability symbol (in this example) »g« is displayed. Add the other components up to the desired weight (formula).

Remove the filled paint can from the load plate.



Never use a hammer to close a paint can while it is still on the load plate, as this will damage the weighing system.

# Applications

## Formulation Mode (Calculation by a Factor)

This mode enables you to weigh in amounts that are smaller or larger than that of your basic formula for a specific paint color (e.g. 250 ml of a 1 l formula). You can select various factors (amounts) by pressing the **[F]** factor key (6):

0.5 1.0 1.5 2.0 2.5 3.0 3.5 4.0 4.5 5.0 10.0 15.0 20.0 25.0.

By pressing the 'Up' (18) **[↑]** key  
or  
you can change the value – in 1.0 increments, as a factor of 5.0  
or  
'Down' (16) **[↓]** key  
– in 0.1 increments, as a factor of 1.0  
– 0.01 increments, up to a factor of 1.0.

### Example:

As you pour the components of your formula, the weight is displayed in »g«.

Let's suppose you want to weigh 3 kg for a basic formula that has a total of 1kg, and you don't want to have to manually recalculate the individual components of the formula. The basic formula for 1 kg is:

	250 g	First component
+	250 g	Second component
+	500 g	Third component
<b>Total:</b>	<b>1000 g</b>	

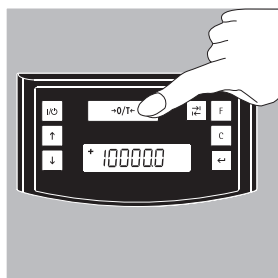

1. Place the empty paint can on the load plate and tare the scale.

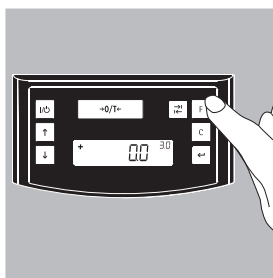

2. Press the **[F]** factor key (6) repeatedly to set the factor to "3.0" for this example.

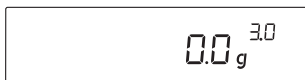

3. »3.0« appears next to the weight readout.

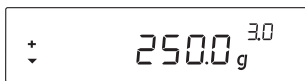

4. Slowly pour in the first component until the display shows »250 g«.



5. Pour in the second component until »500 g« is displayed.



6. Pour in the last component until »1000 g« is displayed.



This concludes the recalculation example.

According to the display, exactly 1000 g was poured in, but the paint can actually contains 3 kg by weight in accordance with the factor you selected (3).

The procedure is the same for any other conversion factor.

### Weighing Using the Recalculation Mode

Let's suppose that you poured in too much of one color component for a given formula (in this example, a 4-component recipe).

This example further assumes that you previously poured in all of the other amounts exactly according to each of the values you entered and saved by pressing the  $\boxed{\leftarrow}$  key [MEM] (8). To correct for the overpour, press the  $\boxed{\downarrow}$  key (16) to start the recalculation program; **C** flashes on the display. Use the  $\boxed{\uparrow}$  key (18; up) or  $\boxed{\downarrow}$  key (16; down) to correct the value so that it matches the amount called for in the formula. Then press  $\boxed{\leftarrow}$  [MEM] (8) to have the scale calculate the amount to be added for each of the components that were already poured. The display shows the amounts required to correct the formula up to the point at which the overpour occurred. After the correction has been completed, you can continue filling the remaining components.

#### Note:

You can correct overpours as often as needed.

Keep in mind that the total quantity of paint at the conclusion of filling increases each time you correct a component. Press the  $\boxed{\text{C}}$  key (7) to check how much the total quantity will be. The **C** stands for "Correction factor."

### Example (Cumulative Weighing)



1. Center an empty paint can on the load plate (15).  
+ 118.0 g



2. Press the  $\square$  key (zero/tare; (3)).  
0.0 g



3. Add first component  
+ 50.0 g



4. Press the  $\square$  key [MEM] (8)  
STO 01



5. Add the second component  
+ 110.0 g



6. Press the  $\square$  key [MEM] (8)  
STO 02



7. Add the third component  
+ 203.0 g  
Oops! You poured in too much.  
The correct value for the formula is 200.0 g.



8. Press the  $\square$  key (16) to start the recalculation mode. A »C« ("Correction") flashes on the display.



9. Press the  $\square$  key (16) repeatedly to correct the value.  
+ 200.0 g



10. Press the  $\square$  key [MEM] key (8)  
COR 01

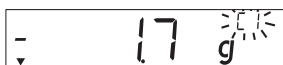

11. The readout shows the amount of the first component to be added, and "C1" is shown in the upper right-hand corner of the display.  
-1.7 g.



12. Add until value reaches  
0.0 g.  
0.0 g



13. Press the  $\square$  key [MEM] key  
COR 02



14. The readout shows the amount of the second component to be added, and "C2" is displayed. - 2.0 g



15. Add until value reaches  
0.0 g.  
0.0 g



16. Press the  $\square$  key [MEM] key (8). The scale returns to the formulation program. »C« is no longer displayed.  
+ 200.0 g.



17. Press the  $\square$  key (7) [REC] to view the factor by which the total weight will exceed the original target defined in the recipe. (C = "Correction;" in this example, 1.03).  
(Total weight = original target  $\times$  correction factor)



18. Add fourth component  
+1000.0 g

This concludes the recalculation example.

# Calibration/Adjustment

You can calibrate/adjust the scale by pressing the  key (Zero/tare) (3).

Calibration weights: 10,000 g; resolution:  $\pm 0.016$  g.

Always allow approximately 30 minutes for the scale to warm up after connecting it to AC power and before performing calibration/adjustment.

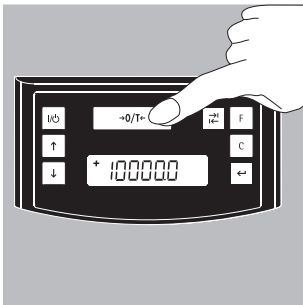
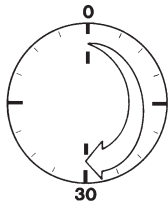

Press the  key (Zero/tare) (3) for 2 seconds; "10000" is displayed. Release the key.

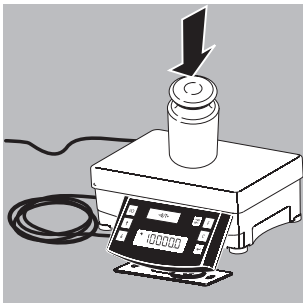

Center the calibration weight on the load plate (15). Adjustment is performed automatically. Remove the calibration weight.

# Menu Settings





SETUP 1

## Accessing the SETUP menu

- ▶  key [ENTER] for approx. 2 seconds, "SETUP" is displayed (level 1).

## Navigating between menu items

- ▶ Select the desired menu item using the   keys.



SETUP 1

## Selecting a lower menu level

The preferred menu item is selected.



- ▶ Press the  key [ENTER] to select the next level down.



SCALE 2

## Setting the menu item

The preferred menu item is selected.

- ▶ Press the  key [ENTER], »« is displayed, the new menu item is set.

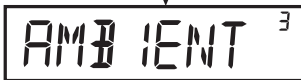

AMBIENT 3



STABLE 4

## Exiting the menu

-  key (Clear) several times to exit the menu.

## Note:

Contact the local Sartorius office for a detailed list of the menu codes

## Configuring the Main Menu Settings

- ▶ Hold down the  key [ENTER] for approximately 2 seconds; "SETUP" is displayed.

Level 1







SETUP

### Language Setting

Level 1    Level 2

LANGUAGE

- o GERMAN
- ENGLISH
- FRENCH
- ITALIAN
- etc.

- ▶ Press the  key to select LANGUAGE
- ▶ Press the  key [ENTER]
- ▶ Press the   keys to select a language
- ▶ Press the  key [ENTER];
  - o indicates the active setting
- ▶ Press the  key repeatedly to exit the menu

### Default Unit: Grams or Parts per Pound

The default settings is active when the scale is switched on; defined under "SETUP > SCALE > UNIT":







Level 1    Level 2    Level 3    Level 4

SETUP

SCALE

UNIT

- o GRAMS
- PT./P.D.

- ▶ Press the  key [ENTER]
- ▶ Press the  key [ENTER]
- ▶ Use the   keys to select the desired setting; e.g., "UNIT"
- ▶ Press the  key [ENTER]
- ▶ Use the   keys to select the desired unit; e.g., "GRAMS"

### Activating the Toggle Key

When the toggle key  (4) is active, you can configure it to toggle the weight unit between grams and parts per pound. The unit is toggled when the key is pressed.











Level 1    Level 2    Level 3    Level 4

SETUP

APPLICATION

TOGGLE

- OFF
- o ON

- ▶ Press the  key [ENTER]
- ▶ Use the   keys to select "APPLICATION"
- ▶ Press the  key [ENTER]
- ▶ Use the   keys to select "TOGGLE"
- ▶ Press the  key [ENTER]
- ▶ Use the   keys to select "ON"
- ▶ Press the  key [ENTER]; o indicates the active setting
- ▶ Press the  key (Clear) repeatedly to exit the menu.

### **Configuring the Toggle-key Function**

Pressing the toggle key  (4) toggles the scale between the default unit (defined under SETUP > SCALE > UNIT; see page 13) and the unit defined as follows under SETUP > APPLICATION > UNIT.

Level 1    Level 2    Level 3    Level 4

---









SETUP

APPLICATION

UNIT

o PT./P.D.

GRAMS

- ▶ Press the  key [ENTER]
- ▶ Use the  keys to select "APPLICATION"
- ▶ Press the  key [ENTER], press  to select "UNIT" and press  to confirm.
- ▶ Use the  keys to select the desired unit; e.g., "PT./PD."
- ▶ Press the  key [ENTER]; o indicates the active setting.
- ▶ Press the  key (Clear)

### **Activating the "LOCK" Function**

The LOCK function protects the scale from unauthorized use. When this function is active, the scale readout shows weight values only when there is active communication between the scale and a PC. If communication is interrupted, the readout goes blank and the display shows a padlock symbol. Activation of the LOCK function is configured under "EXTRAS."

Level 1    Level 2    Level 3    Level 4

---









SETUP

EXTRAS

LOCK

OFF

o ON

- ▶ Press the  key [ENTER]
- ▶ Use the  keys to select "EXTRAS"
- ▶ Press the  key [ENTER]
- ▶ Use the  keys to select "LOCK"
- ▶ Press the  key [ENTER]
- ▶ Use the  keys to select ON and press  to confirm
- ▶ Press the  key (Clear) repeatedly to exit the menu.

---

### Configuring Password Protection

In addition to the LOCK function, you can configure password protection for additional security. With this feature, the LOCK function can be deactivated only by entering the password you configure. The password is numeric and can have up to 6 digits. Use the  $\uparrow$ / $\downarrow$  keys to select the digits (0 through 9) for your password. The password is hidden on the readout; only dashes ("-----") are shown. The first dash flashes to prompt input. Press the  $\uparrow$ / $\downarrow$  keys as needed to select the desired digit (0 to 9) and then press the  $\leftarrow$  key [ENTER] key. The digit is stored and the second dash flashes on the display. Repeat the input procedure as described for the first digit. To store a space as a character in the password, press the  $\leftarrow$  key [ENTER] while the corresponding dash is flashing. Once all 6 characters have been stored, press the  $\leftarrow$  key [ENTER] to store the password.

Note:

Keep a copy of your password in a safe place.

The LOCK function can be deactivated only with this password.

Level 1    Level 2    Level 3

---

INPUT

PASSWORD

PW.NEW

-----

- ▶ Use the  $\uparrow$ / $\downarrow$  keys to select "INPUT"
- ▶ Press the  $\leftarrow$  key [ENTER]
- ▶ Press the  $\leftarrow$  key [ENTER]
- ▶ Use the  $\uparrow$ / $\downarrow$  keys to select "PW.NEW"
- ▶ Enter the desired password and press the  $\leftarrow$  key [ENTER]
- ▶ Press the  $\text{C}$  key (Clear) repeatedly to exit the menu

### Changing the Password

To define a new password, the existing password must be entered first in the SETUP menu under "PASSWORD." "PW.OLD" prompts this input. Once the old password is entered, the "PW.NEW" prompt is shown automatically. Enter the new password or press  $\leftarrow$  at each position to enter spaces. The display shows spaces.

Note:

Entering 6 spaces deletes the password, which deactivates the password function.

Level 1    Level 2    Level 3

---

INPUT

PASSWORD

PW.OLD

-----

PW.NEW

-----

- ▶ Use the  $\uparrow$ / $\downarrow$  keys to select "INPUT"
- ▶ Press the  $\leftarrow$  key [ENTER]
- ▶ Press the  $\leftarrow$  key [ENTER]
- ▶ Enter the existing (old) password
- ▷ After the old password have been entered correctly, "PW.NEW" is displayed.
- ▶ Enter the desired password and press the  $\leftarrow$  key [ENTER]
- ▶ Press the  $\text{C}$  key (Clear) to return to the menu

---

## Configuring Text Length ("LONG" or "SHORT")

You can define the length of the operator guidance texts shown on the display.

Level 1    Level 2    Level 3    Level 4

---

SETUP

EXTRAS

TEXTS

LONG

o SHORT

- ▶ Press the  key [ENTER]
- ▶ Use the   keys to select "EXTRAS"
- ▶ Press the  key [ENTER]
- ▶ Use the   keys to select "TEXTS"
- ▶ Press the  key [ENTER]
- ▶ Use the   keys to select "SHORT" and press  to confirm
- ▶ Press the  key (Clear) repeatedly to exit the menu

## Resetting the Scale: "RESET"

You can restore the factory settings in the scale.

Note:

If you have activated the password function, this feature is password-protected.

Level 1    Level 2    Level 3    Level 4

---

SETUP

RESET

MENU

YES

o NO

- ▶ Press the  key [ENTER]
- ▶ Use the   keys to select "RESET"
- ▶ Press the  key [ENTER]
- ▶ Use the   keys to select "MENU"
- ▶ Press the  key [ENTER]
- ▶ Use the   keys to select "YES"
- ▶ Press the  key. Factory settings are restored. "MENU" is displayed
- ▶ Press the  key (Clear) repeatedly to exit the menu

## Code Settings

Select the "CODES" menu item to have menu items identified by numeric codes rather than texts.

Level 1    Level 2

---

LANGUAGE

GERMAN

etc.

o CODES

- ▶ Press the  key to select LANGUAGE
- ▶ Press the  key [ENTER]
- ▶ Use the   keys to select "CODES"
- ▶ Press the  key [ENTER]; o indicates the active setting
- ▶ Press the  key (Clear) repeatedly to exit the menu

Note:

Contact your local Sartorius office for a detailed list of the menu codes.

---

# Troubleshooting Guide

<b>Problem</b>	<b>Cause</b>	<b>Solution</b>
No segments appear on the display	– No AC power is available	– Check the AC power supply
The weight readout shows "LOW"	– No load plate on the scale	– Position the load plate
The weight readout shows "HIGH"	– Weighing capacity exceeded	– Unload the scale
The weight readout changes constantly	– Unstable ambient conditions – Too much vibration, or the scale is exposed to a draft	– Set up the scale in another area – Access the menu to select the appropriate code for the ambient conditions (see "Menu Settings")
The weight readout is obviously incorrect	– The sample is not stable – Scale not tared before weighing	– Tare the scale before weighing
No weight value is shown and the padlock symbol is displayed 	– PC connection to the scale has been interrupted activating the LOCK function	– Access the menu settings to deactivate the LOCK function – Check the connection

---

# Care and Maintenance

## Cleaning

- △ Never use concentrated acids, alkali solutions or pure alcohol to clean the equipment.
- △ Do not allow liquids to penetrate the equipment housing.
- ▶ Use a brush or a soft, dry, lint-free cloth to clean the scale.

## Storage and Shipping Conditions

- ▶ The packaging used for shipping your Sartorius equipment is optimally designed to prevent damage during transport. It is a good idea to save the box and all parts of the packaging for future storage or shipment of the equipment.
- ▶ Please refer to the information under "Safety Inspection" below.

## Safety Inspection

Safe operation of the scale is no longer ensured in the following cases:

- There is visible damage to the AC adapter/power supply or cables
  - The equipment no longer functions properly
  - The equipment has been stored for a relatively long period under unfavorable conditions
  - The equipment has been subjected to rough handling during shipment
- ▶ Observe all warnings and safety precautions. In this case, notify the Sartorius Service or the International Technical Support Unit based in Goettingen, Germany. Maintenance and repair work may only be performed by authorized Sartorius service technicians who have access to the required maintenance manuals and have received the necessary training.

---

# Disposal

## Information on Decontamination

The device does not contain any hazardous materials that would necessitate special disposal actions.

Contaminated samples used during the process are potentially hazardous materials that could cause biological or chemical hazards.

If the device has come into contact with hazardous substances: Steps must be taken to ensure proper decontamination and declaration. The operator is responsible for adhering to local government regulations on the proper declaration of transport and disposal and the proper disposal of the device.

---

**⚠ Warning**  
**Risk of injury due to contaminated devices!**

Devices contaminated with hazardous materials (NBC contamination) will not be accepted by Sartorius for repair or disposal.

---

## Dispose of Device and Parts

### Information on Disposal

The device and the device accessories must be disposed of properly by disposal facilities.

A lithium cell battery, type CR2032, is installed inside the device. Batteries must be disposed of properly by disposal facilities.

The packaging is made of environmentally friendly materials that can be used as secondary raw materials.

### Disposal

#### Requirements

The device has been decontaminated.

#### Procedure

- ▶ Dispose of the device. Follow the disposal instructions on our website ([www.sartorius.com](http://www.sartorius.com)).
- ▶ Dispose of the packaging in accordance with local government regulations.

---

# Interface Description

---

## ⚠ Notice

The PMA35001-Y is equipped with a 25-pin D-SUB female socket. Only data transfer is allowed: Neither the PMA35001-Y is supplied with power via this data output nor should this scale supply the connected device with energy. The external devices are usually connected via the supplied adapter cable.

---

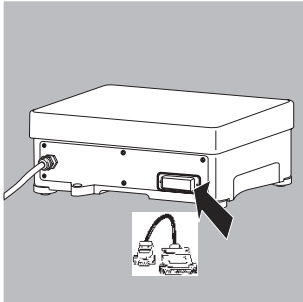

## Mounting the adapter cable

The scale can only be operated on a PC via an RS232 data cable if you connect the adapter cable. If you wish to create your own application software, Sartorius can supply the required drivers for DOS or WINDOWS operating systems.

⚠ Make sure to observe the safety instructions.

- ▶ Remove the protective cover from the interface port. Keep the protective cover in a safe place.
- ▶ Replace the interface cover when storing or shipping the scale.
- ▶ Plug in the adapter cable and tighten the retaining screws.

# Technical Data

Type		PMA 35001-Y
Weighing range	g	35000
Readability	g	0.1
Tare range (subtractive)	g	-35000
Max. linearity	g	<±0.2
Stabilization time, configured via menu	digit	0.25 to 4
Humidity class	F	non-condensing
Ambient operating temperature range	°C	0...+40
Storage temperature	°C	-20...+70
Allowable humidity during storage	%	max. 90
Highest rel. humidity	%	80, for temperatures up to 31°C, decreasing linearly up to 50% relative humidity for 40 °C.
IP protection	IP	43, as per IEC/EN60529
Ambient conditions		Indoor use only. Height up to 2,000 m. Supply voltage fluctuations up to ±10% of the supply voltage. Overvoltage Category II, Pollution Degree 2
Load plate dimensions	mm	350 × 240
Scale housing (W × D × H)	mm	350 × 243 × 132.5
Net weight, approx.	kg	11.4
Calibration weight	kg	10, Class F1 or better
Power consumption	VA	Average: 8, max. 16
Interface		RS232
- Format		7-bit ASCII, 1 start bit, 1 or 2 stop bits
- Parity		Even, odd, none
- Transmission rates		1200 to 38,400 bps
- Handshake		Software or hardware
<b>Explosion protection</b>		according to DIN EN/IEC 60079-0: Explosive atmospheres – Part 0: Equipment - General requirements
<b>Electromagnetic compatibility</b>		According to EN 61326-1: Electrical equipment for measurement, control and laboratory use – EMC requirements – Part 1: General requirements
Interference immunity:		Industrial areas
Transient emissions:		Class B: suitable for use in residential areas and areas that are directly connected to a low voltage network.

---

# Accessories

<b>Item</b>		<b>Order no.</b>
In-use dust cover		YDC01PMA
RS232 data cable	(2 m)	YCC01-0047M2
USB/RS232 data cable	(2 m)	YCC01-USBM2
Adapter cable 25 to 9 pin	(0.2 m)	69PM0057

# Documents

SARTORIUS



Original

## EU-Konformitätserklärung EU Declaration of Conformity

Hersteller **Sartorius Lab Instruments GmbH & Co. KG**  
Manufacturer **37070 Goettingen, Germany**

erklärt in alleiniger Verantwortung, dass das Betriebsmittel  
*declares under sole responsibility that the equipment*

Geräteart **Hochlastige Farbmischwaage**  
Device type **High-capacity paint mixing scale**

Modelle **PMA35001-Y**  
Models

in der von uns in Verkehr gebrachten Ausführung allen einschlägigen Bestimmungen der folgenden Europäischen Richtlinien entspricht und die anwendbaren Anforderungen folgender harmonisierter Europäischer Normen einschließlich deren zum Zeitpunkt der Erklärung geltenden Änderungen erfüllt:

*in the form as delivered fulfils all the relevant provisions of the following European Directives and meets the applicable requirements of the harmonized European Standards including any amendments valid at the time this declaration was signed listed below:*

	EMV   EMC	RoHS	Explosionsschutz   Explosion Protection
Richtlinie Directive	2014/30/EU	2011/65/EU	2014/34/EU
Norm(en) Standard(s)	EN 61326-1:2013 EN IEC 61326-1:2021	EN IEC 63000:2018	EN IEC 60079-0:2018 EN 60079-11:2012

Kennzeichnung **II 3G Ex nA ic IIB T4 Gc**  
Marking

EG-Baumusterprüfbescheinigung Nummer **DEKRA 19ATEX0006 X**  
EC-Type Examination Certificate number

Die Person, die bevollmächtigt ist, die technischen Unterlagen zusammenzustellen:  
*The person authorised to compile the technical file:*

Sartorius Lab Instruments GmbH & Co. KG  
Electronics & Product Compliance  
37070 Goettingen, Germany

Sartorius Lab Instruments GmbH & Co. KG  
Goettingen, **2024-07-05**

**Mario Hesper**  
Managing Director

**Halil Yildirim**  
Senior Compliance Manager

Doc: 2014154-03 SLI14CE014-03.de,en 1 / 1 PCF: 2014123 GP-124F-00

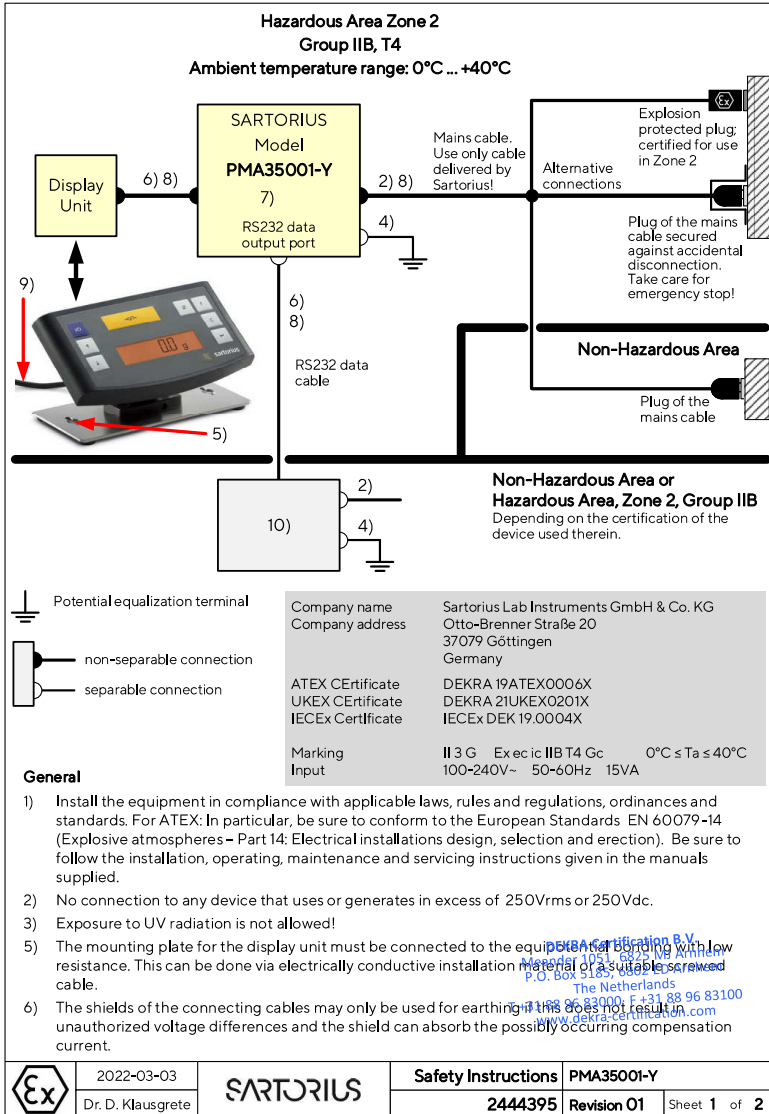

	2022-03-03	<b>SARTORIUS</b>	<b>Safety Instructions</b>	<b>PMA35001-Y</b>
	Dr. D. Klausgrete		<b>2444395</b>	<b>Revision 01</b>

- 8) The connecting cable of the display unit and all external connecting cables (especially the power cord) must be protected against damage and tensile load caused by strain. The cable connections in the Ex area must be secured against self-loosening and the screw connections must be screwed tight. Third-party cables are the responsibility of the operator. **WARNING – DO NOT CONNECT OR DISCONNECT WHEN ENERGIZED.**
- 9) The connection cable of the display unit must be secured in such a way that it can not be damaged by kinking on the sharp-edged cable inlet of the display unit.
- 10) A device connected to the PMA35001-Y must be certified for use in the area, where it shall be used, and the cable to the PMA35001-Y must contain only data lines (voltages lower than 30Vdc) in type of protection Ex ec. Observe the marking, in particular the permissible gas group and temperature class of this device.
- 11) Use equipment only in the temperature ranges indicated. Avoid exposing the equipment to heat.
- 12) At reasonable intervals, have your equipment installation checked for proper functioning and safety by a trained and certified technician.
- 13) Keep chemicals and other agents, which can corrode the housing seals and cable sheaths, away from the equipment. These agents include oil, grease, benzene, acetone and ozone. If you are not sure about the safety of a certain substance, please contact the manufacturer.
- 14) **WARNING: SUBSTITUTION OF COMPONENTS MAY IMPAIR INTRINSIC SAFETY.**  
If your equipment needs to be repaired, use only original spare parts supplied by the manufacturer!
- 15) Any tampering with the equipment by anyone, other than repair work done by authorized Sartorius service technicians, will result in the loss of EX conformity and in the forfeiture of all claims under the manufacturer's warranty. Only authorized specialists may open the equipment.
- 16) Modifications, including those to be carried out by Sartorius employees, may be permitted only after the express written authorization has been obtained from Sartorius.
- 17) If the equipment does not operate properly, unplug it immediately from line power (mains supply)!
- 18) **WARNING – DO NOT OPEN WHEN ENERGIZED.** Prior to opening the equipment, disconnect the power supply or make sure that there is no potentially explosive atmosphere or any other explosion hazard in the surrounding area!

#### Specific Conditions of Use

- 4) The protective ground connectors on the equipment shall be connected together using a potential equalisation conductor with a cross-sectional area of at least 4 mm<sup>2</sup>. The low resistance of this connection to the PA bus bar must be checked when the system is installed at the intended place of use. The shielding of the connecting cables may only be used for grounding when no impermissible difference in voltage is generated and, if necessary, the shielding is able to conduct the equipotential current.
- 7) The equipment shall be installed in such a way that it is protected against the entry of solid foreign objects or water capable of impairing the safety of the apparatus. It shall be installed in such a way that the pollution degree 2 of the internal electronics is guaranteed. Reduce the risk of mechanical damage to a minimum. Unused openings must be sealed with suitable caps (do not remove under load)!
- 19) Parts of the enclosure of the equipment are non-conducting and may generate an ignition-capable level of electrostatic charges under certain extreme conditions. The use of the equipment is not installed in a location where it may be subjected to external conditions that might cause a build-up of electrostatic charges on non-conducting surfaces, additionally, cleaning of the equipment should be done only with a damp cloth.

Dekra Certification B.V.  
 Mendel 101, 8513 VV Alphen  
 P.O. Box 215, 8511 ZH Alphen  
 T +31 88 96 83000 - F +31 88 96 83100  
[www.dekra-certification.com](http://www.dekra-certification.com)

	2022-03-03	<b>SARTORIUS</b>	<b>Safety Instructions</b>	<b>PMA35001-Y</b>
	Dr. D. Klausgrete		<b>2444395</b>	<b>Revision 01</b>

# CERTIFICATE

## (1) Type Examination

(2) **Product intended for use in potentially explosive atmospheres - Directive 2014/34/EU**

(3) Type Examination Certificate Number: **DEKRA 19ATEX0006 X** Issue Number: **0**

(4) Product: **Paint mixing scale, type PMA35001-Y**

(5) Manufacturer: **Sartorius Lab Instruments GmbH & Co. KG**

(6) Address: **Otto-Brenner-Straße 20, 37079 Göttingen, Germany**

(7) This product and any acceptable variation thereto is specified in the schedule to this certificate and the documents therein referred to.

(8) DEKRA Certification B.V., certifies that this product has been found to comply with the Essential Health and Safety Requirements relating to the design and construction of products intended for use in potentially explosive atmospheres given in Annex II to Directive 2014/34/EU of the European Parliament and of the Council, dated 26 February 2014.

The examination and test results are recorded in confidential test report no. NL/DEK/EXTR19.0004/00.

(9) Compliance with the Essential Health and Safety Requirements has been assured by compliance with:

EN 60079-0 : 2012 + A11 : 2013      EN IEC 60079-0 : 2018  
 EN 60079-11 : 2012                      EN 60079-15 : 2010

except in respect of those requirements listed at item 18 of the Schedule.

(10) If the sign "X" is placed after the certificate number, it indicates that the product is subject to the Specific Conditions of Use specified in the schedule to this certificate.

(11) This Type Examination Certificate relates only to the design and construction of the specified product and not to the manufacturing process and its monitoring.

(12) The marking of the product shall include the following:



II 3 G Ex nA ic IIB T4 Gc

Date of certification: 5 March 2019

DEKRA Certification B.V.

L.G. van Schie  
 Certification Manager

Page 1/2

Integral publication of this certificate and adjoining reports is allowed. This Certificate may only be reproduced in its entirety and without any change.



(13) **SCHEDULE**

(14) **to Type Examination Certificate DEKRA 19ATEX0006** Issue No. 0

(15) **Description**

The Paint mixing scale, type PMA35001-Y, consists of a weighing module in a painted aluminum enclosure, an interconnection cable and a remote display unit in a plastic enclosure.

The enclosures provide a degree of protection of at least IP4X in accordance with IEC 60079-0.

Ambient temperature range 0 °C to +40 °C.

The internal circuits are non-sparking 'nA'. Protection method 'ic' is used for the keyboard push buttons.

**Electrical data**

AC power input: 100...240 VAC; 50/60 Hz; 15VA;  $U_n = 264$  VAC.

RS232 interface (D-SUB socket);  $U_{max} = \pm 12$  V.

The internal secondary circuits are connected to the earthed metal enclosure.

**Installation instructions**

The instructions provided with the product shall be followed in detail to assure safe operation.

(16) **Report Number**

No. NL/DEK/ExTR19.0004/00.

(17) **Specific conditions of use**

The equipment shall be installed in such a way that:

- it is protected against the entry of solid foreign objects or water capable of impairing the safety of the apparatus.
- the risk for mechanical damage is low.
- it cannot be subjected to UV light.

Static charging of the plastic parts of the enclosure shall be avoided. Use a damp cloth for cleaning the equipment.

(18) **Essential Health and Safety Requirements**

Covered by the standards listed at item (9).

(19) **Test documentation**

As listed in Report No. NL/DEK/ExTR19.0004/00.

(20) **Certificate history**

Issue 0 - 223356900 initial certificate

Page 2/2

Form 244  
Version 1 (2016-04)



# IECEX Certificate of Conformity

## INTERNATIONAL ELECTROTECHNICAL COMMISSION IEC Certification System for Explosive Atmospheres

for rules and details of the IECEX Scheme visit [www.iecex.com](http://www.iecex.com)

Certificate No.:	<b>IECEX DEK 19.0004X</b>	Page 1 of 4	<a href="#">Certificate history:</a>
Status:	<b>Current</b>	Issue No: 1	<a href="#">Issue 0 (2019-03-05)</a>
Date of Issue:	2022-03-29		
Applicant:	<b>Sartorius Lab Instruments GmbH &amp; Co. KG</b> Otto-Brenner-Straße 20, 37079 Göttingen Germany		
Equipment:	<b>Paint mixing scale, type PMA35001-Y.</b>		
Optional accessory:			
Type of Protection:	<b>Ex ec, Ex ic</b>		
Marking:	<b>Ex ec ic IIB T4 Gc</b>		

Approved for issue on behalf of the IECEX  
Certification Body:

**R. Schuller**

Position:

**Certification Manager**

Signature:  
(for printed version)

Date:  
(for printed version)

1. This certificate and schedule may only be reproduced in full.
2. This certificate is not transferable and remains the property of the issuing body.
3. The Status and authenticity of this certificate may be verified by visiting [www.iecex.com](http://www.iecex.com) or use of this QR Code.



Certificate issued by:

**DEKRA Certification B.V.**  
Meander 1051  
6825 MJ Arnhem  
Netherlands





## IECEx Certificate of Conformity

Certificate No.: **IECEx DEK 19.0004X**

Page 2 of 4

Date of issue: 2022-03-29

Issue No: 1

Manufacturer: **Sartorius Lab Instruments GmbH & Co. KG**  
Otto-Brenner-Straße 20, 37079 Göttingen  
**Germany**

Manufacturing locations: **Sartorius Lab Instruments GmbH & Co. KG**  
Otto-Brenner-Straße 20, 37079 Göttingen  
**Germany**

This certificate is issued as verification that a sample(s), representative of production, was assessed and tested and found to comply with the IEC Standard list below and that the manufacturer's quality system, relating to the Ex products covered by this certificate, was assessed and found to comply with the IECEx Quality system requirements. This certificate is granted subject to the conditions as set out in IECEx Scheme Rules, IECEx 02 and Operational Documents as amended

#### STANDARDS :

The equipment and any acceptable variations to it specified in the schedule of this certificate and the identified documents, was found to comply with the following standards

[IEC 60079-0:2017](#) Explosive atmospheres - Part 0: Equipment - General requirements  
Edition:7.0

[IEC 60079-11:2011](#) Explosive atmospheres - Part 11: Equipment protection by intrinsic safety "I"  
Edition:6.0

[IEC 60079-7:2017](#) Explosive atmospheres - Part 7: Equipment protection by increased safety "e"  
Edition:5.1

This Certificate **does not** indicate compliance with safety and performance requirements other than those expressly included in the Standards listed above.

#### TEST & ASSESSMENT REPORTS:

A sample(s) of the equipment listed has successfully met the examination and test requirements as recorded in:

Test Report:

[NL/DEK/EXTR19.0004/01](#)

Quality Assessment Report:

[GB/FME/QAR13.0020/05](#)



## IECEx Certificate of Conformity

Certificate No.: **IECEx DEK 19.0004X**

Page 3 of 4

Date of issue: 2022-03-29

Issue No: 1

### EQUIPMENT:

Equipment and systems covered by this Certificate are as follows:

The Paint mixing scale, type PMA35001-Y..., consists of a weighing module in a painted aluminum enclosure, an interconnection cable and a remote display unit in a plastic enclosure.

The enclosures provide a degree of protection of at least IP4X in accordance with IEC 60079-0.

Ambient temperature range 0 °C to +40 °C.

Protection method 'ic' is used for the keyboard push buttons.

Module type name: The two dots behind the Y are characters that represent not safety relevant module variations.

### Electrical data

AC power input: 100...240 VAC; 50/60 Hz; 15VA;  $U_{nT}=264$  VAC.

RS232 interface (D-SUB socket):  $U_{max} = +/- 12$  V;  $I_{nom} < 35$  mA.

The internal secondary circuit is connected to the earthed metal enclosure.

### SPECIFIC CONDITIONS OF USE: YES as shown below:

The equipment shall be installed in such a way that:

- it is protected against the entry of solid foreign objects or water capable of impairing the safety of the apparatus.
- the area provide at least pollution degree level 2, as defined in IEC 60664-1.
- the risk for mechanical damage is low.
- it cannot be subjected to UV light.

Static charging of the plastic parts of the enclosure shall be avoided. Use a damp cloth for cleaning the equipment.



## IECEx Certificate of Conformity

Certificate No.: **IECEx DEK 19.0004X**

Page 4 of 4

Date of issue: 2022-03-29

Issue No: 1

**DETAILS OF CERTIFICATE CHANGES (for issues 1 and above)**

Assessment per IEC 60079-7 for protection Ex ec.  
Removal protection Ex nA.

Sartorius Lab Instruments GmbH & Co. KG  
Otto-Brenner-Strasse 20  
37079 Goettingen, Germany

Phone: +49 551 308 0  
[www.sartorius.com](http://www.sartorius.com)

The information and figures contained in these instructions correspond to the version date specified below.

Sartorius reserves the right to make changes to the technology, features, specifications and design of the equipment without notice.

Masculine or feminine forms are used to facilitate legibility in these instructions and always simultaneously denote all genders.

Copyright notice:

These instructions, including all components, are protected by copyright.

Any use beyond the limits of the copyright law is not permitted without our approval.

This applies in particular to reprinting, translation and editing irrespective of the type of media used.

Last updated:

12 | 2024

© 2024  
Sartorius Lab Instruments GmbH & Co. KG  
Otto-Brenner-Str. 20  
37079 Goettingen, Germany

SP | Publication No.: WPM6064-e241208