

SPSY

SPSY SERIES SINGLE POINT STAINLESS STEEL LOAD CELLS



Stainless steel load cells for off center loads, suitable for example to build CE-M approved scales with a single load cell with maximum dimensions of 500x400 mm.

CAPACITIES (kg): 10, 20, 50, 100.

OIML R60. C3 precision class.

17-4 PH stainless steel. **IP68/IP69K** protection.

Working in cooperation with:

P.R.S. TORFBUD DAWID SZOPA
11 LISTOPADA 8 - 41500 - CHORZOW - POLAND
Tel. 0048-322413522 Fax. 0048-322413522
torfbud@wagielektroniczne.com.pl

The best solution
for advanced industrial
applications

MAIN FEATURES

- C3 PRECISION CLASS
- OFF CENTER LOAD COMPENSATED
- MADE IN 17-4 PH STAINLESS STEEL
- IP68/IP69K PROTECTION
- MAX. CAPACITIES FROM 10 TO 100 kg
- FOR PLATFORMS WITH DIMENSIONS UP TO 500 X 400 mm
- SHIELDED CONNECTION CABLE
- TEST CERTIFICATE AVAILABLE UPON REQUEST

TECHNICAL FEATURES

- Minimum load cell verification interval: $V_{min} = E_{Max} / 10.000$
- Maximum number of verification intervals: $n_{LC} = 3000$
- Full Scale Output: $2mV/V \pm 10\%$
- Temperature effect on zero:
 $\pm 0,014\% \text{ F.S./}10K$
- Temperature effect on full scale output:
 $\pm 0,0117\% \text{ F.S./}10K \text{ (-}10^{\circ}C/+20^{\circ}C)$
 $\pm 0,0175\% \text{ F.S./}10K \text{ (+}20^{\circ}C/+40^{\circ}C)$
- Compensated Temperature Range: $-10^{\circ}C/+40^{\circ}C$
- Operating Temperature Range: $-10^{\circ}C/+50^{\circ}C$
- Creep at nominal load in 30 minutes: $\pm 0,01\% \text{ F.S.}$
- Maximum tolerated excitation voltage: 15 VDC
- Input Resistance: $380 \pm 15 \text{ Ohm}$
- Output Resistance: $350 \pm 10 \text{ Ohm}$
- Insulation Resistance (100V) $>2000 \text{ MOhm}$
- Safe Overload: 150% F.S.
- Ultimate Overload: 300% F.S.
- Nominal displacement: $< 0.5 \text{ mm}$
- 6-wire shielded cable, 3m long, 5mm diameter

DETAIL 1

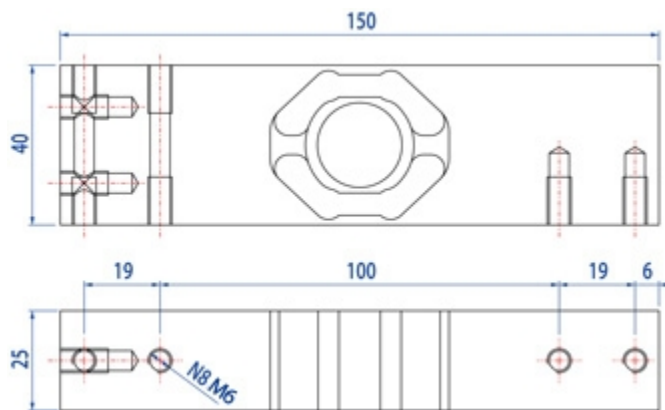



Dimensions in mm

<u>Wiring Code</u>	
<i>Colour</i>	<i>Function</i>
WHITE	OUTPUT +
GREEN	SENSE +
BLUE	INPUT +
RED	OUTPUT -
BLACK	INPUT -
GREY	SENSE -

VERSIONS

Available versions

Codice	Piatto Max (mm)	Max (kg)
SPSY10 	500 x 400	10
SPSY20 	500 x 400	20
SPSY50 	500 x 400	50
SPSY100 	500 x 400	100



www.diniargeo.com

“YOUR WORLDWIDE PARTNER FOR WEIGHING”

DINI ARGEO
FRANCE sarl
France

DINI ARGEO
GMBH
Germany

DINI ARGEO
UK Ltd
United Kingdom

DINI ARGEO WEIGHING
INSTRUMENTS Ltd
China

DINI ARGEO
OCEANIA
Australia



COMPANY HEADQUARTERS

Via Della Fisica, 20
41042 Spezzano di Fiorano - Modena - Italy
Tel. +39.0536 843418

P.R.S. TORFBUD DAWID SZOPA

11 LISTOPADA 8 - 41500 - CHORZOW - POLAND

Tel. 0048-322413522 Fax. 0048-322413522

torfbud@wagielektroniczne.com.pl

SALES AND TECHNICAL ASSISTANCE SERVICE