

GI 400 USER'S GUIDE

EN

WEIGHT-TARE / PIECE COUNTING
ANALOGICAL / DOSAGE / LIMITS

V.3.1_20170908



LED

LCD

GIROPES

Pol. Empordà Internacional Calle F. Parcela 15-16
17469 VILAMALLA - (Girona) SPAIN
T. (34) 972 527 212 - F. (34) 972 527 211

EN

1. MECHANICAL DESCRIPTION	3
1.1 FRONT PANEL	3
1.2 BACK PANEL	5
2. CONNECTION	6
2.1 PHASE OF TEST	6
2.2 DISPLAY OF THE NUMBER OF SERIES	6
2.3 SETTING THE INITIAL ZERO	6
3. EXECUTABLE FUNCTIONS	7
3.1 SETTING THE SCALE TO ZERO	7
3.2 WEIGHT	7
3.3 TARE, CONSECUTIVE TARES, GROSS-NET	7
3.4 BLOCKING/UNBLOCKING TARE	7
3.5 MANUAL TARE	7
3.6 ACCUMULATION	7
3.7 CONTINUOUS MANUAL ACCUMULATIONS	8
3.8 TOTAL OF THE WEIGHTS	8
4. FUNCTION MENU	8
4.1 CALCULATION OF THE UNIT WEIGHT <i>CALPMU</i>	9
4.2 PIECE COUNTING <i>PMU</i>	9
4.3 CHECKWEIGHER <i>CHECKT</i>	9
4.4 IT SHOWS THE WEIGHT WITH A DECIMAL MORE FOR ACURACY <i>by 10</i>	12
4.5 ACCUMULATION <i>ACUMUL</i>	12
4.6 SUBTOTAL <i>Subtot</i>	13
4.7 CODE <i>t. Code</i>	13
4.8 NUMBER OF TICKET <i>n. t.c</i>	13
4.9 DATE <i>--DATE--</i>	13
4.10 TIME <i>--t:ME--</i>	14
4.11 INTERNAL COUNTS <i>iCount</i>	14
4.12 WEIGHT MODE <i>WEIGHT</i>	14
4.13 DOSAGE <i>dos.F.</i>	14
4.14 LIMITS <i>Lim:LE</i>	15
4.15 ANALOG EXIT 4-20MA / 0-10V <i>Analog</i>	17
4.16 MEMORIZED TARE <i>TLU</i>	18
4.17 DATA VISUALISATION <i>ALIBI EMPOR 153</i>	18
5. NO METROLOGICAL TECHNICAL MENU	18
5.1 MENU <i>PARAME</i> ; COM1, COM2 Y RS485	19
5.1.1 Frame	20
5.1.2 Baud rate	20
5.1.3 Protocolo	20
5.1.4 Ind.Add	20
5.1.5 <i>t.r.99r</i> (Modo de transmisión)	21
5.2 ETHERNET MENU	22
5.3 CONFIGURATION MENU	24
5.4 TEST	25
6. PRINTER	25
6.1 FORMAT OF TICKETS	25
7. MESSAGES OF ERROR	28
8. CONNECTIONS	28
9. DSD MEMORY	31
10. LOAD CELL CONNECTOR	32
11. REMOVAL OF ELECTRONIC EQUIPMENT	33
12. OPTIONAL BATTERY	33
13. WARRANTY	33

1. MECHANICAL DESCRIPTION

1.1 FRONT PANEL

LED

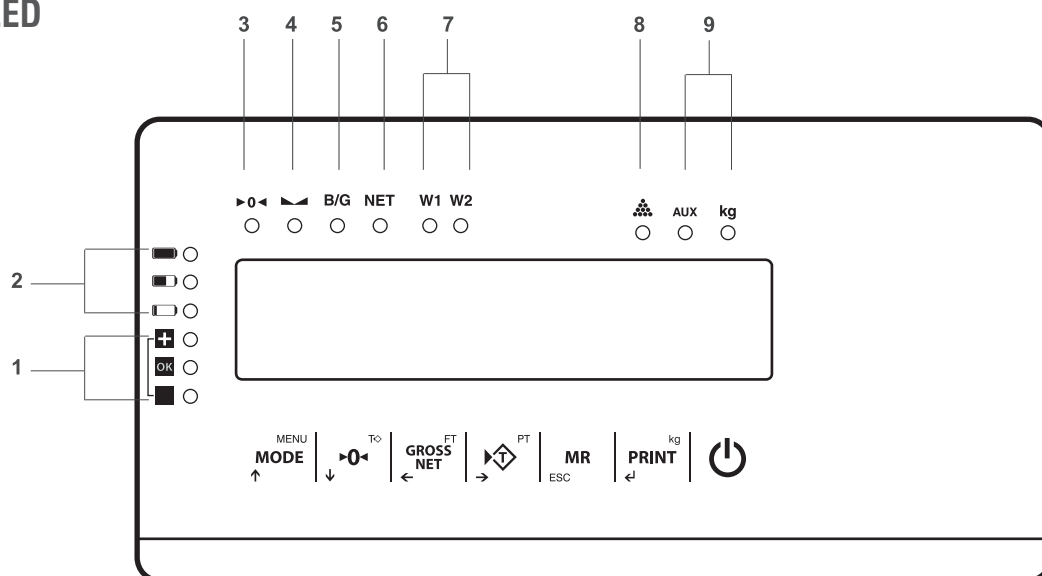



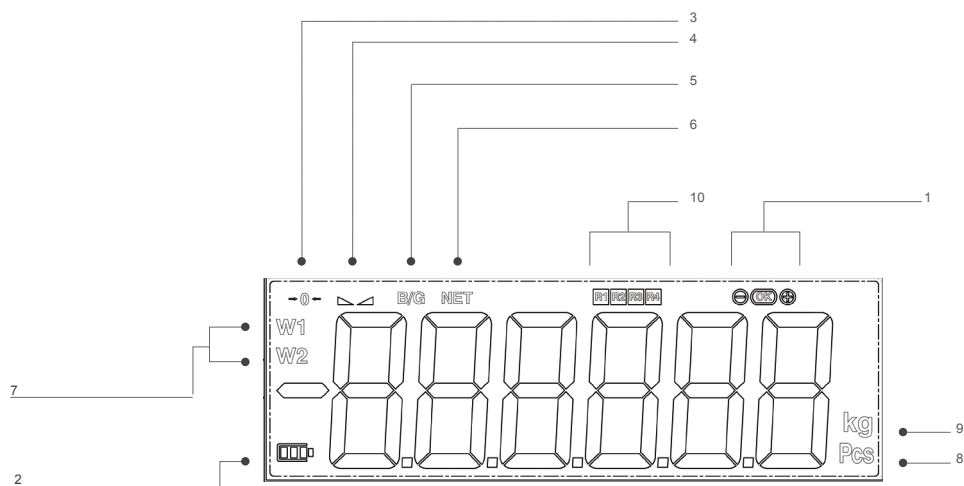



LCD







1	Signal of limits (checkweigher)
2	Signal of level of battery (work with battery optional)
3	Signal of zero
4	Signal of steady weight
5	Gross weight
6	Net weight
7	Weighing range
8	Piece counting
9	Units of measure
10	Signal of relays (only for LCD)



KEYBOARD

	Access to the user's and technician's menu
	Do Zero / Remove tare
	Show Gross/Net/ Set tare
	Do the tare / Introduce tare manually
	Total of weights prints total accumulation / Exit
	Printing / Sending of manual weight / Selector of unit (for lb version only)
	Switch on / Switch off

CURSOR KEYS

	Move editable digit to right side
	Move editable digit to left side
	Increases selected digit
	Decreases selected digit

KEYS ENTER AND ESCAPE

	Erase the current value Keep press to exit
	Validate the selected value

1.2 BACK PANEL

INOX IP54

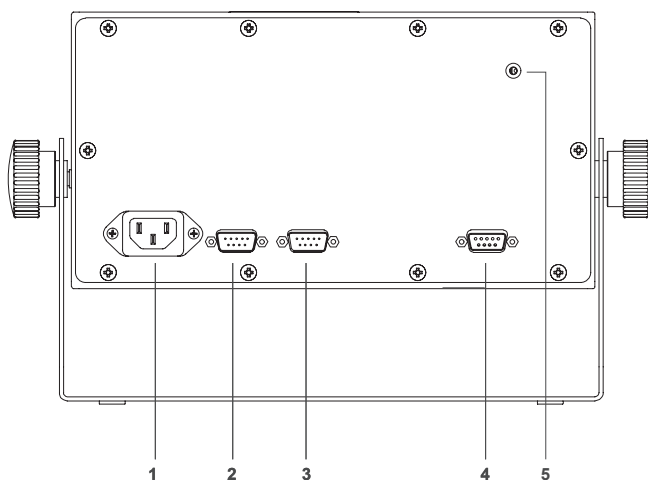

INOX IP65

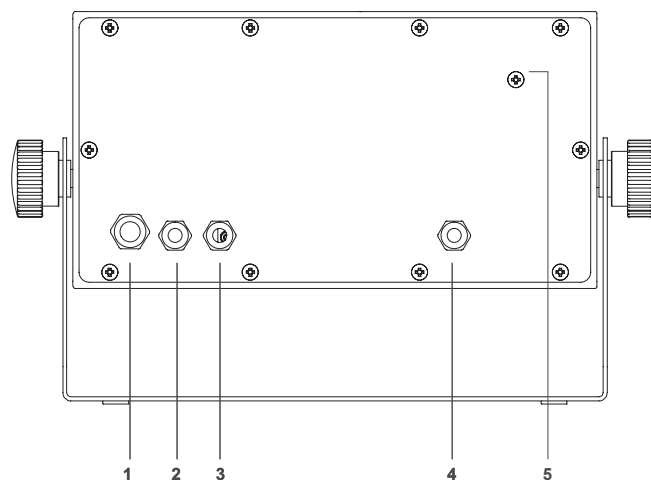

- 1 **Power connector IEC**
- 2 **Connector RS232-Com1** (SubD 9 male tracks)
- 3 **Connector RS232-Com2** (SubD 9 male tracks)
- 4 **Connector Load cell** (SubD 9 female tracks).
- 5 **Calibration switch**

- PG9 for power cable**
- PG7 for RS232-COM1**
- PG7 for RS232-COM2**
- PG7 for load cell cable**
- Calibration switch**

ABS IP54

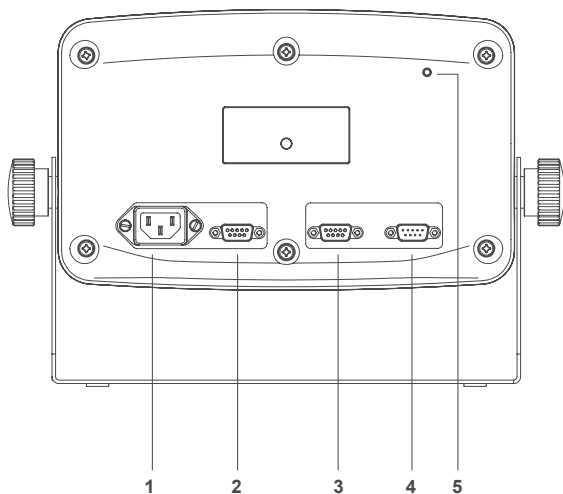

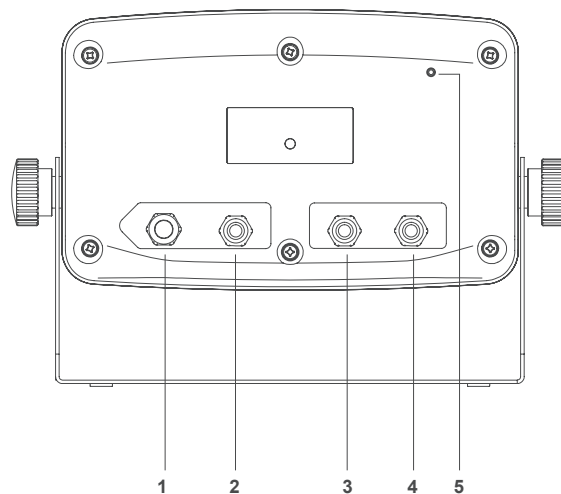

ABS IP65



- 1 **Power connector IEC**
- 2 **Connector RS232-Com1** (SubD 9 male tracks)
- 3 **Connector RS232-Com2** (SubD 9 male tracks)
- 4 **Connector Load cell** (SubD 9 female tracks).
- 5 **Calibration switch**

- PG9 for power cable**
- PG7 for RS232-COM1**
- PG7 for RS232-COM2**
- PG7 for load cell cable**
- Calibration switch**

2. CONNECTION

Connect the terminal to the platform through a DB9 connector. To switch on the terminal you must press for some seconds the key . To switch off the terminal it is necessary to press for some seconds the key ; but to switch off the terminal completely it can only be done by disconnected the terminal from the electrical connection.

2.1 PHASE OF TEST

DISPLAY	DESCRIPCIÓN
<i>9 1400 or 9 1401</i>	In first place it appears the model of the equipment. (<i>9 1400</i> =GI400) or (<i>9 1401</i> =GI401)
<i>L0.003</i>	Next it will show the version of the programmer
<i>8.8.8.8.8.8</i>	Then it will appear all LEDs and display segments turned ON. (ONLY LED VERSION)
<i>U 1.0 10</i>	After that appears the version of the user's software
<i>9rAut</i>	This is followed by the message
<i>9.804</i>	Then displays the value of gravity set
<i>n cal:b</i>	Then the message number of calibrations, followed by the corresponding value appears.
<i>9 1.0 16</i>	It appears on the screen the message of internal version
<i>P x.xxx</i>	Finally it appears on the screen software version weighing.

2.2 DISPLAY OF THE NUMBER OF SERIES

If during the phase of test display the user presses the key  the device is going to show the serial number.

ABC 123

2.3 SETTING THE INITIAL ZERO

When connecting the indicator it will start the setting of zero of the scale, to do so the following conditions are necessary:

1. Steady weight (luminous sign of steady weight  on;
2. Value of weight not inferior to the -10% of the Max. in relation to the zero of calibration of the scale;
3. Value of weight not superior to the 10% of the Max. in relation to the zero of calibration of the scale.

During the development of the operation of zero setting the display is going to show the following message:

CEro

If the weight is steady but out of the range of zero the display is going to blink for about 1 second more or less.

N.B. The user can't do any operation until the setting of zero has been done

The precision of the setting of zero is inside and not out of the division: 0,25e

3. EXECUTABLE FUNCTIONS

3.1 SETTING THE SCALE TO ZERO

When the user presses the key  assumes the metrological function of weight zeroing, in the modality described below, in reference to the current regulations.

1. Steady weight (the bright sign of steady weight  is on);
2. Value of weight not inferior to the -2% of the Max. in relation to the zero of calibration of the scale;
3. Value of the weight not superior to the 2% of the Max. in relation to the zero of calibration of the scale.

The brilliant sign  indicates that the function has been done.

3.2 WEIGHT

The device switches on a led of stability when a weight is placed on the platform and when the weight is steady. When the scale is unloaded the device switches on the zero and stability leds.

3.3 TARE, CONSECUTIVE TARES, GROSS-NET

To do a tare the user must press the key . When this key is pressed the indicator is going to show immediately the net weight, and the Net led switches on.

If the user wants to do another tare, s/he needs to press the key  again.

To know the gross weight (container plus contents) the user must press the key . On the display the led Net switches off and the sign of gross weight B/G switches on.

If the user presses this key again  the device is going to go back to the net weight and the led of Net is going to switch on again.

3.4 BLOCKING/UNBLOCKING TARE

If the user wants to block the used tare in the previous section, so that it does not disappear the possibility to use the same are in a consecutive way, the user must press for some seconds, at least 2, the key tare . The value of tare remains blocked. The display informs the operation showing "Tar. Blo".

To unblock the tare the user must keep pressed 2s the key . The display is going to indicate this action by showing the message "Tar. Sbl" on the screen

NOTE: ALSO IS POSSIBLE TO SET THE INDICATOR FOR LOCK THE TARE AUTOMATICALLY. SEE POINT 5.3

3.5 MANUAL TARE

The terminal allows the incorporation of a manual tare by pressing during two seconds the key . The user must use cursor, escape and enter keys for input new tare value. If procedure before is used, tare value will keep locked till you unlock it.

3.6 MEMORIZED TARE TLU

The indicator has 5 memorized tases: tlu1, tlu2, tlu3, tlu4 and tlu5.

Before use this function, it must to be set on menu "mode". For access to this menu follow the steps described in **section 4** and see the procedure in **section 4.16**. The tare value keeps lock until it is unlocked with the procedure of the previous section.

3.7 ACCUMULATION (ONLY WORKS WITH PRINT PROTOCOL ACTIVATED)

The user can not use this fonction without activating it first. To do it the user must go to the menu “*ModE*”. To go to the menu the user must follow the steps described in **the section number 4** and watch the procedure in the **section 4.5**.

Each time that accumulation is done, the message *RCC* appears on screen.

This message disappears after some seconds and it shows and it shows again the value of the last weight placed on the platform. If the user has a printer connected to the terminal, the printer prints a line with net weight.

3.7.1 SUCCESSIVE MANUAL ACCUMULATIONS

Place the weigh on the scale, press  key when stable indication turns on.

If we want to accumulate again, press the key  again.

The indicator will continue memorizing if: the scale has been unlocked previously or tare is done or adicional weigh has been added.

3.7.2 SUCCESSIVE AUTO ACCUMULATIONS

Place the weigh on the scale, when it takes stability it will accumulate.







The indicator will continue memorizing if: the scale has been unlocked previously or tare is done or adicional weigh has been added.

3.8 TOTAL OF THE WEIGHTS

If one of accumulation modes is active, once all desired weights had been accumulated and the scale is in zero the user wants to know the total of the weights s/he must press the key . The terminal is going to show the total number of weights and the total net weight.

- If there is a printer defined in the parameters of rs232 and connected, a ticket is going to be printed.
- If the user presse the key  the device is going to release another print of the ticket, except if format 7 is selected in which a repeat of the total is printed.

4. FUNCTION MENU

DISPLAY	DESCRIPTION
<i>ModE</i>	<ul style="list-style-type: none"> • The user can access to this menu by pressing the key  • The display is going to show the message <i>ModE</i> on the screen and next it will appear the first available function.
	<ul style="list-style-type: none"> • The user must use the keys described bellow to select the desired function.
	<ul style="list-style-type: none"> - Inside a menu increases the value of the selected number. - It goes to the previous function.
	<ul style="list-style-type: none"> - It goes to the next function. - Inside a menu, decreases the selected value.
	<ul style="list-style-type: none"> - Inside a menu, goes back memorizing the value set. - It selects the current function.
	<ul style="list-style-type: none"> - If the user keeps this key pressed s/he can exit from the function without memorizing the value set (function ESC). - With short press, returns to zero the current value.
	<ul style="list-style-type: none"> - Move to the right side the edition digit.
	<ul style="list-style-type: none"> - Move to the left side the edition digit.

THE AVAILABLE FUNCTIONS ARE:

<i>CALAW</i>	CALCULATION OF THE UNIT WEIGHT
<i>AWU</i>	PIECE COUNTING
<i>CHECK</i>	CHECKWEIGHER
<i>by 10</i>	IT SHOWS THE WEIGHT WITH A DECIMAL MORE FOR ACCURACY
<i>ACCUMUL</i>	ACCUMULATION
<i>Subtot</i>	SUBTOTAL
<i>L Code</i>	SET PRODUCT CODE
<i>n. L.C</i>	SET TICKET NUMBER
<i>DATE</i>	DATE
<i>Time</i>	TIME
<i>WEIGHT</i>	WEIGHT MODE
<i>dos.F.</i>	DOSAGE (only with additional board 4I/40 (relay))
<i>ANALOG</i>	ANALOG OUTPUT (only with additional board analog)
<i>LIMIT</i>	LIMITS (only with additional board 4I/40 (relay))
<i>TU</i>	TARE MEMORY
<i>dsd</i>	FISCAL MEMORY (only with additional board ALIBI)

4.1 CALCULATION OF THE AVERAGE UNIT WEIGHT *CAL AWU*

This function calculates the unit weight of the pieces through the piece counting program. To calculate the average unit weight the user must place a number of known pieces on the platform and the press the key **PRINT**^{kg}. The screen of the display is going to show the message *SP.xxxx*. The user must then introduce, using the keys, the number of pieces that make the sample.

To calculate and register the value of the average unit weight the user must press the key **PRINT**^{kg}.

The terminal shows- during two seconds- the message "*WE.Ur.*" on the screen, followed by the unit weight of the piece. After that, the indicator goes back to the weight mode and shows the number of pieces in the scale.

If the user presses the key **PRINT**^{kg} and there is no weight on the platform or the weight is inferior to the necessary to calculate it on the screen, the display is going to show the message "*add*". This message indicates that more pieces are needed so that the calculation can be done.

4.2 PIECE COUNTING *AWU*

This function is used to do the calculation of the pieces loaded on the platform. It does so by taking the programmed average weight (**PMU**). The indicator asks for the **PMU** by showing the message *Px.xxxx*. The user must introduce the value of the unit weight using the cursor keys. Press **PRINT**^{kg} key to confirm.

4.3 CHECKWEIGHER *CHECK*

This function activates the mode "**CHECK WEIGHER**" or the mode goes-not-goes .

The equipment is ready to manage automatically up to **4 zones** through limits of weight for each one of them.

When the user accesses the menu *CHECK* the first parameter s/he must configures is the menu *LArset*: this menu programs the value of the target of weight that the user wants to achieve. Is the central value of OK zone.

After that the user must choose the type of **TARGET** between *type 1* and *type 2*. To access must enter the parameter *CHU T4*. Once selected you can choose between *type1* and *type2*.

4.3.1 TTYPE1 *TYPE*

If the user chooses the *TYPE 1* it allows to choose the inferior limits and the superior ones with a **percentage** of the TARGET value.

Exemple:

-PC. 0 10 (We chose how lower limit 10% below the Target)

PC. 0 10 (We chose how upper limit 10% above the Target)

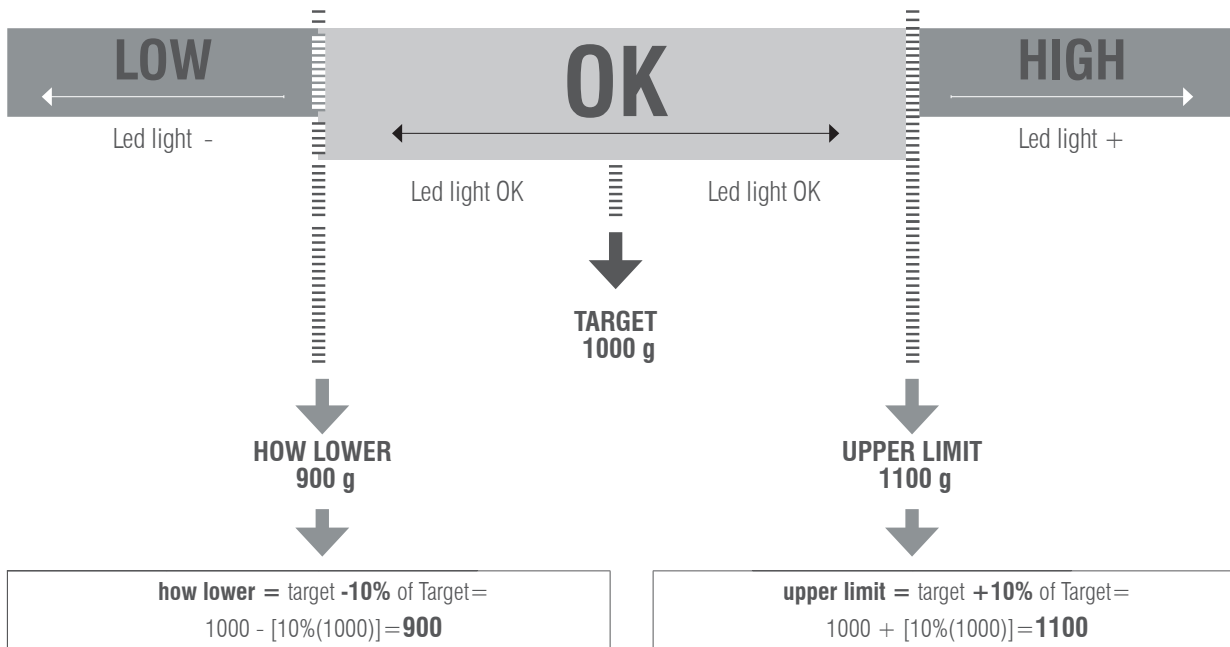

4.3.2 TTYPE2

If the user chooses the *TYPE 2* it allows to choose the inferior and superior limits directly: *LOWL XXXXX ; HighL XXXXX*

Exemple:

LOWL 800

HighL 1200

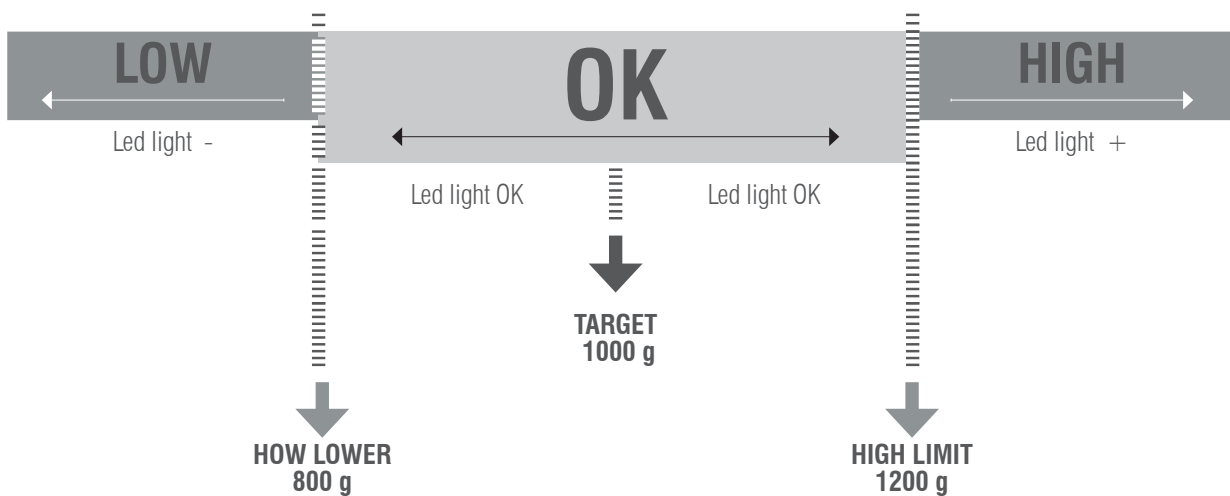

Once they are configured, the **TARGET** value and the **LIMITS**, the program ask the user to configure the limit of the **ALARM**. The alarm programs the value with any value above this one is going to activate the alarm sign, and 3 lights are going to bright. Finally the user must choose the alarm sound. He can choose between *btype 1* or *btype 2*.

4.3.3 BTYPE1

If the user chooses the btype 1 can to choose between the:

- bmode 1*: no beep sound
- bmode 2*: a short beep sound, when access the OK zone, it can be done above or below.
- bmode 3*: a long beep sound, when access the OK zone, it can be done above or below,

4.3.4 BTYPE2

If the user chooses the btype 2 can to choose between the:

- bmode 1*: with no beep sound
- bmode 2*: short beep sound when moving away from the superior or inferior limit $\pm 2\%$ FS
- bmode 3*: long beep sound when moving away from the superior or inferior limit $\pm 2\%$ FS

EXAMPLE;

TARGET = 1000g
 FS = 15000 g
 Active btype2 and ALARM is 3000g.
 high limit = 2200g
 low limit = 1800g

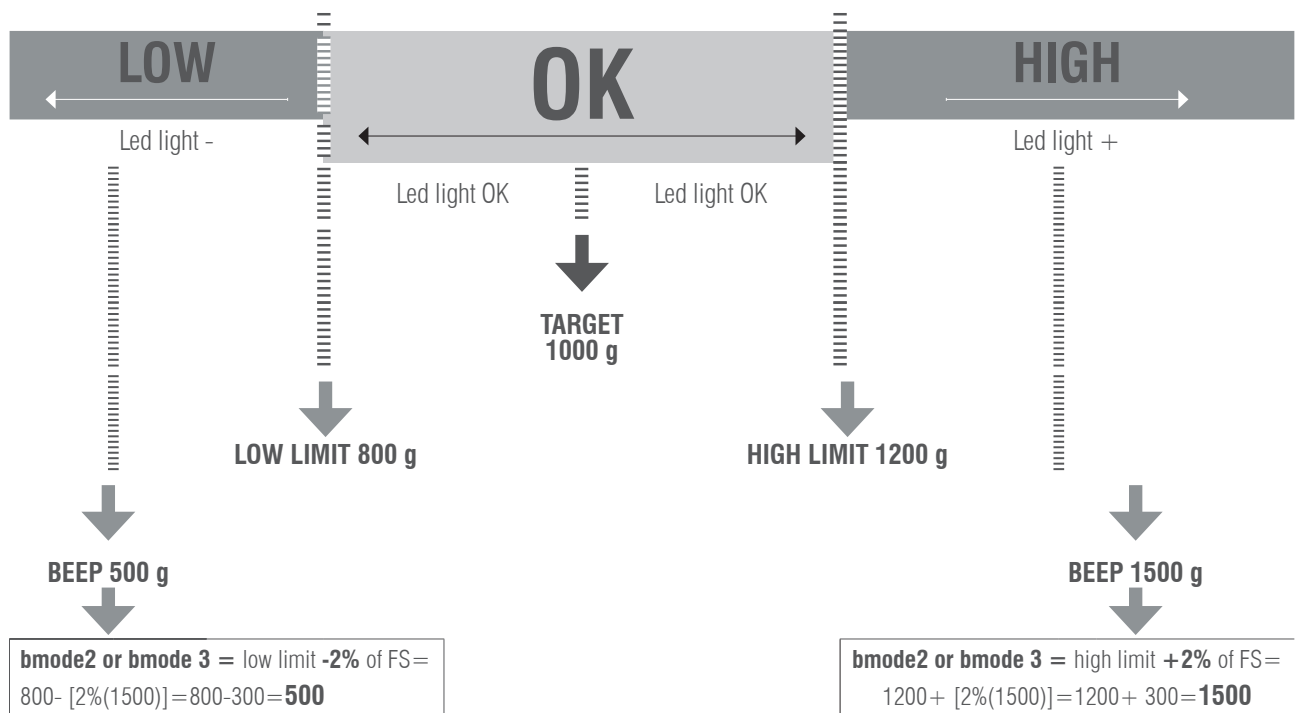

NOTE: ZONE OK

This value is activate, when the value of the weight is superior to the inferior limit and inferior to the superior limit, the green LED is going to activate

FULL EXAMPLE;

FS = 15000 g
 Active btype2, mode 2 or 3.

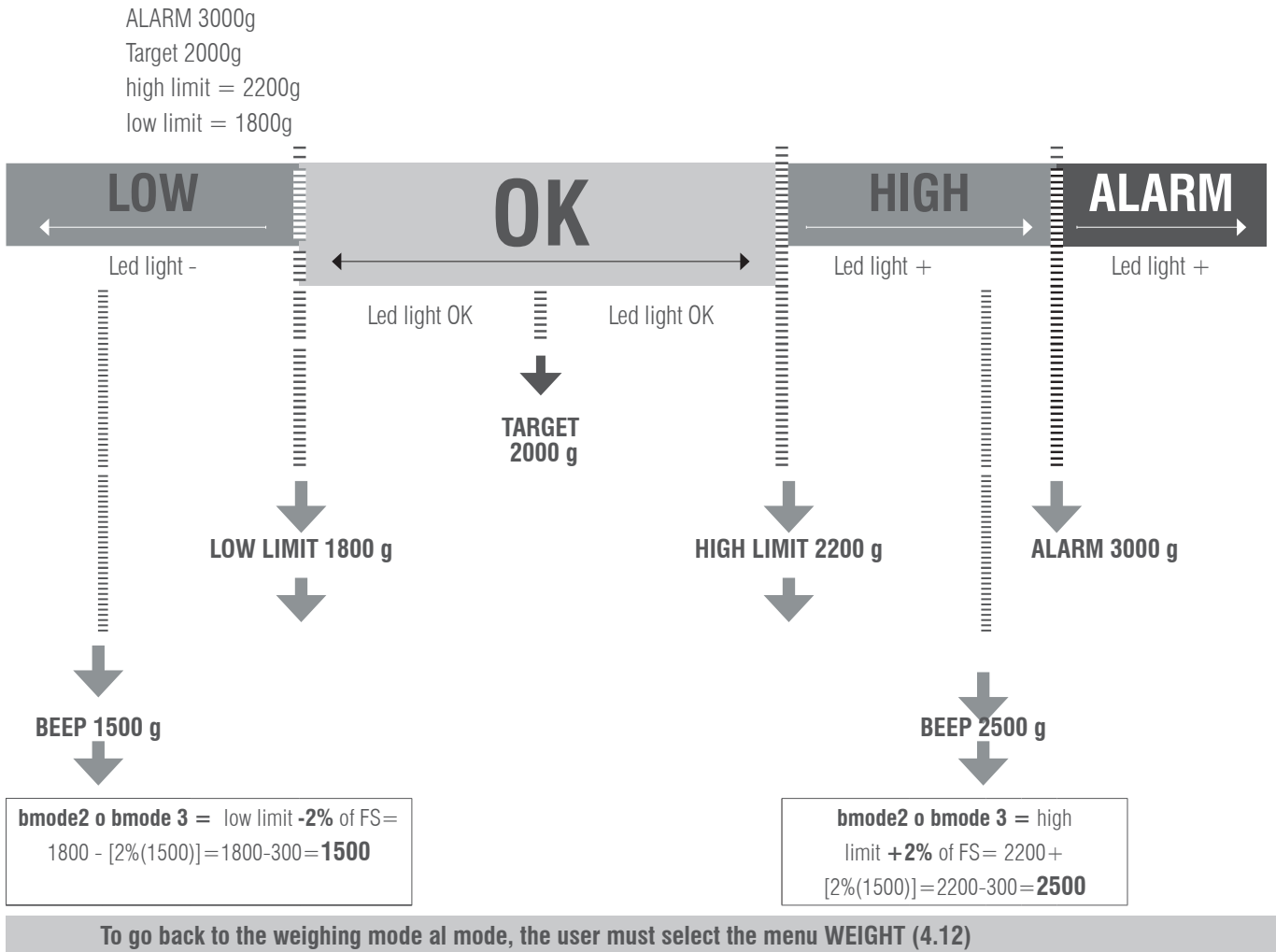

4.4 IT SHOWS THE WEIGHT WITH A DECIMAL MORE FOR ACCURACY *by 10*

With the selection of this function the indicator displays a decimal more in the weight.

Once this function is authorized there is an activation of the display. In this situation the less significant number of the display gets activated and it indicates the value per 1/10 of the division of the verification. The decimal moves but the display does not increase a digit.

With the device connected, the display of the data of weight does not respect the metrological indication. It is for this reason that while it is activated all the communication with the series channel is inhibited. The display remains active for a period of approximately **6 seconds**, after this time the terminal, automatically, sets the display in normal weight. Being out of legal metrology, the device keeps extra accuracy till user press **MR** | **ESC** key.

4.5 ACCUMULATION *ACUMUL*

This function carries out the process of auto accumulation and ticket printing

TO MAKE THE AUTO-ACCUMULATION FUNCTION WORK, IT IS NECESSARY TO SELECT FIRST THE PROTOCOL PRINT IN COM1 OR COM2, AS IT IS DESCRIBED IN THE SECTION 5 OF THIS MANUAL

1.

DISPLAY	STEPS
<i>ACUMUL</i>	<ul style="list-style-type: none"> Press the key PRINT^{kg} <p>THE DISPLAY IS GOING TO SHOW ONE OF THE LEGENDS DETAILED BELOW</p>
<i>ACCoff</i>	
<i>ACCAut</i>	
<i>ACCMan</i>	

The user must choose them with the keys **MODE**^{MENU} and **0**^{TO}, the selected option is memorized by pressing the key **PRINT**^{kg}.

2.

DESCRIPTION: ACCOFF, ACCAUT AND MANACC, AND CONFIGURATION

<i>ACCoff</i>	<ul style="list-style-type: none"> ACCUMULATION OFF The accumulation mode is deactivated
<i>ACCAut</i>	<ul style="list-style-type: none"> AUTO ACCUMULATION The accumulation mode is automatic. In the moment of detecting steady weight the device does the accumulation automatically. Once this function is validated the terminal shows on its display the message (nA xxxx). The user must introduce the desired value of the number of accumulations using the following keys: If this value is DIFFERENT FROM 0 the system continues with the accumulation of weights until it reaches the prearranged value. If the programmed value is 0, the weights are accumulated until the user decides to press the key MR_{ESC} (limit 9999). (Totalization)
<i>ACCMan</i>	<ul style="list-style-type: none"> ACCUMULATION MANUALLY The mode of accumulation is done manually by pressing the key PRINT^{kg}. The weight must be stable and must change from accumulation before. It will accumulate till the user press MR_{ESC}.

4.6 SUBTOTAL *Subtot*

With this function the user can see the number of accumulated weights and the total weight up to the actual moment. The screen displays first the number of weights and next it automatically shows the total accumulated weight. This function does not entail the elimination of the number of weights and the total of weight.

4.7 TOTALITZATION

By pressing **MR**_{ESC} key device shows totalitization value. If one printer mode is selected, the total ticket will be printed. By pressing again **MR**_{ESC} key will print a copy. Making a new accumulation after **MR**_{ESC} the memory will be erased.

4.8 CODE *t. Code*

This function allows the introduction of a code which is added to the printed ticket. To introduce this code the user must use the keys specified below.

THIS OPTION IS ONLY VALID USING PROTOCOL PRINTER WITH THE OPTION PRNF9 ACTIVATED.

4.9 NUMBER OF TICKET *n. TIC*

With this function the user can print in the ticket a ticket number which is going to increase automatically at the end of the weight, (number of delivery or number of ticket). Use the cursor keys for change the value and enter escape to exit or memorize.

4.10 DATE *DATE*

Function for updating the date, with format day/month/year use the cursor keys for to change the value and enter/escape to memorize/exit.

EXAMPLE: 17.03.14

4.11 TIME *TIME*

Function for updating setting of the time, with format hour/minute/second. Use the cursor keys for change the value and enter/escape for memorize/exit.

EXAMPLE: 19.05.59

4.12 WEIGHT MODE *WEIGHT*

The user access the normal mode of weighing again.

4.13 DOSAGE *doS.F.*

IT ONLY WORKS WITH AN OPTIONAL RELAYS BOARD (4I/4O)

With 4 inputs and 4 outputs. The dosing function is only available when the plate is correctly connected to the display.

The card has four relays with potential-free output up to 0.5A 125VAC or 2A 30VDC. With them you can check remote instruments such as relays, signal lamps and PLC. The card also has four inputs. The 4 inputs are emulated to the keys of the equipment when they are in dosage mode. The dosing function remains active until it is switched off.

The equipment is ready to dose automatically with two different possibilities: 1 product at two speeds or 2 products at one speed, with unload. The device allows the programming, for each product, of the weight of the value of the thickness or product 1, and the value of the weight when the device works at slow speed (that is the value of the smooth) or the value of the product 2.

The device can also program a zone of unload where it is defined the value of the dosage(to correct the blocking of the system because there is product left in the weighing zone).

When the equipment starts working it automatically functions with the last formula it has worked with. This allows the device to start again with its daily work.

When the user gets into the menu to program the dosage "doSiFi", the following menu is going to appear on the screen:

doS.F.	<i>reset</i>	YES / NO	yes-no (It sets the process to zero, it also places all the weights to ZERO)
	<i>P.PROD 1 W</i>	WEIGHT	thick weight to program or weight of the product 1
	<i>T.PROD 1 L</i>	TIME	time of lack of material, if the weight on the screen does not change in this space of time, it activates the relais of alarm.

<i>P.PROD 2</i>	WEIGHT	smooth weight to program or weight of the product 2
<i>T.PROD 2</i>	TIME	Time of lack of material
<i>P.Z.DISC</i>	WEIGHT	Maximum waste weight
<i>T.Z.DISC</i>	TIME	Time of zero, when the zero is activated a time to wait for the falling of the material is also activated
<i>C. Tare</i>	AUTO/NO	Make, or not, auto tare when dosage starts
<i>ENABLE</i>	SI / NO	

RESET

By selecting YES, all parameters are set zero.

By selecting NO, you can access directly to the parameters to modify them.

PROD1

It edits the values of the formula for the product 1. If the weight is programmed to 0, the equipment is going to dosify the product 2.

- **WEIGHT:** The desired weight for this product is programmed.
- **TIMER:** Time of lack of material, if the weight on the screen does not vary in this space of time, it is going to activate the alarm (RL4).

PROD2

It edits the values of the formula for the product 2. If the weight is programmed at 0, the equipment will dosify only the product 1.

- **WEIGHT:** The desired weight for this product this product added to product 1 weight is programmed.
- **TIMER:** Time of lack of material, if the weight on the screen does not vary in this space of time, it is going to activate the relais of alarm. (RL4)

Z.DISC

- **WEIGHT:** This option programs the weight within which the equipment determines that the dosage has been finished, (maximum of possible waste weight that may stay without the alarm ringing)
- **TIMER:** Time waste of material, if the weight on the screen does not vary in this space of time, it is going to activate the relais of alarm. (RL4)

ENABLE

It exits from the menu of dosage and asks to the user if he wants to get start doing the dosage. To start doing the dosage appears on the display the legend - DOS – The keys will do the functions specified below:

Note:

The value of timers must be bigger than 000,0 s. for assure the capacity of activate the alarm (RL4). If you want that RL4 (alarm) will never be activated, keep timers to 0s.

ENTRANCE EXT.	KEY INDICATOR	FUNCTION
INPUT 1	PRINT ^{kg} ↵	START key
INPUT 2	MR ESC	STOP Key
INPUT 3	PT ↻	RESTART key
INPUT 4	GROSS NET ^{FT} ←	ABORT key / exits from the DOSI function and goes back to the normal mode. You need to press two times if you use the indicator key.

Note:

If the alarm is activated (RL4), press key STOP and then RESTART for continue where it was stopped.

4.14 ANALOG EXIT 4-20mA / 0-10V (ONLY FOR LED DEVICES!)

ACCESS TO THE MENU IS POSSIBLE ONLY WHEN THE CARD IS CONNECTED

This card allows the exit of 4-20mA or 0-20mA or 0... +10V or 2... +10V, proportional to the gross weight or the net weight in the scale.

The exit of the current is active and supplies the necessary voltage.

The analog exit is actualized every 50ms and acquires the appropriate value of the weight, converted into in that moment. It is for this reason that if the filter in the weight is decelerated, the analogical exit is also decelerated.

To do the setting of the parameters, the user must access to:

<i>AnALog</i>	
<i>4-20mA</i>	REQUESTING THE FULL SCALE (U MAX) IN KG THAT WILL DELIVER 20mA.
<i>0-10V</i>	REQUESTING FULL SCALE (U MAX) IN KG THAT WILL DELIVER 10V.
<i>ADJUST</i>	AN MIN OUTPUT FOR NEGATIVE WEIGHT
	AN ZER OUTPUT FOR ZERO WEIGHT
	AN MAX DEPARTURE FOR THE FUND ALLOCATED SCALE (U MAX)
<i>ENABLE</i>	SELECT YES / NO TO ACTIVATE OR DEACTIVATE FUNCTIONALITY

The setup process begins by selecting the operating mode, either 4-20mA or 0-10V depending on the type of output you want. At this point you must specify the full scale **U MAX** which must be equal to or less than the full scale of the scale.

When the back of the scale is confirmed, the device starts the establishment of values of the analog exit, or the values of the digital/analog converter are introduced (comprised between 0 and 65535), for these values it is appropriated a determined value of exit in voltage or current.

In this configuration the keys of the device acquire the following functions:

An MAX

It establishes the magnitude of the analog exit, be that in current or voltage, when the scale displays the maximum weight, which is going to belong to the previous FS programmed.

An ZEr

It establishes the magnitude of the analog exit, be that in current or voltage, when the scale displays the minimum weight, which is going to belong to the Zero of the scale.

An m.in

It establishes the minimum value of the analog exit. With this value we adjust so that the equipment gives a value below 4 mA or 0v. It also allows us to program the magnitude of the signal when the value loaded on the platform is below zero, belonging to the condition underload.

Example

We are going to take as example a hopper scale with a back of scale of 300kg. Of this scale we only use the range up to 200kg for the exit of 20mA as this is the maximum capacity of the hopper.

In F.S we will introduce 200kg and we will adjust the value of An_Max so that in the exit we can register 20mA with a multimeter or an automaton. Next we are going to go to the parameter An_Zer and adjust the value to obtain 4mA in the exit; with this we are going to have a perfect measuring range of 200kg and 16mA. In the parameter An_Min we are going to introduce a value so that we can read the negatives to up to the 3mA. In the case that the automaton does not allow it, we will adjust the zero to 5mA. The measuring range is going to be of 200kg and 15mA.

4.15 LIMITS *L:ML*

THEY ONLY WORKS WITH THE OPTIONAL RELAYS BOARD

The equipment is able and thought to manage automatically up to 4 limits through registers of weight for each one of them.

These registers are called

- Start
- Low Limit (Low.L.)
- High Limit (High. L.)
- Alarm

The associated relays is always activated when the weight of the scale is placed between the two limits.

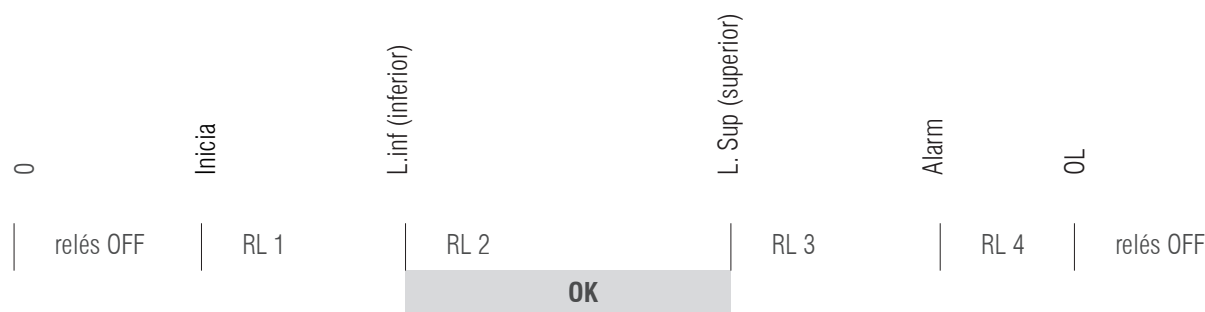

As each relay is in fact a commute circuit, taking the normally closed contacts, the user is going to obtain the inverse sign of the previous figure.

When we go to the function of the programming of limits (*L:ML*), the following menu is going to appear on the screen:

RESET?	NO	Goes to next parameter without erase the information.
	YES	It places at 0 all the relays so that it deactivates all of them.
StArt		It programs the value, every value above this one is going to activate the relays of the L:INF, RELAYS 1 (<i>S xx.xxx</i>)
L. Low		It programs minimum value, every value below this one is going to activate the relays of the L:INF, RELAYS 1 (<i>L xx.xxx</i>)
O.K.		This value can not be programmed but it activates the RELAYS 2 whenever the value of the weight is superior to Low L and inferior to the High L
L. High		It programs the high value, every value above this one is going to activate the relays of the L.SUP, RELAYS 3 (<i>H xx.xxx</i>)
ALARM		it programs the high value, every value above this one is going to activate the relays of alarm, RELAYS 4 (<i>A xx.xxx</i>)
ENABLE		Exit from the menu limits and start to apply them if YES is choosed. If we choose NO exit from the menu and doesn't apply the limits stored on memory.

NOTES: THE FUNCTION OF THE LIMITS IS AUTOMATIC WHEN IT EXITS FROM THE ZERO RANGE. THE LIMIT FUNCITON CONTINUES ACTIVATE TILL USER DESACTIVATES IT.

ENTRANCE EXT.	KEY INDICATOR	FUNCTION
Input 4		ABORT key, turns off limit function and returns to weight mode with external pushbutton, IN4, and with display key.

4.16 MEMORIZED TARE *TLU*

For input tare value on TLU menu, first select option Edit choose the TLU number with cursor key. Confirm with key and press for come back to weighing mode.

For activate a memorizing tare, on the menu, select *SLECC*, and choose the desired TLU number, confirm with , the indicator will return on weighing mode with tare activated.

To erase all memorized tares, on *TLU* menu, select *ERASE* option and confirm with .

4.17 DATA VISUALISATION *MEMORY DSD*

THEY ONLY WORKS WITH THE OPTIONAL ALIBI BOARD

- Accessing to DSD menu (only available if DSD memory is installed) the indicator give access to DSD file to see the weights stored with fiscal memory process.
- The indicator will show the last code in use, with cursor keys you can input the desired value.
- On last line it shows the current weight.
- Then, operator must input the weighing number about he/she want fet data of brut and tare.
- If data is not stored, it will show an error message, if all is correct, it will show weighing data.

For exit from data menu, keep pressed key some seconds.
During data viewing "Tx" function from PC will not work.

5. NO METROLOGICAL TECHNICAL MENU

In this page the user can find the description of the options of the LIMITED PROGRAMATION. Functions to personalize ONLY the configuration of the NO METROLOGICAL PART (printers, peripherals, analog exits and relays):

- The procedure of the limited programming is done by pressing for a long time the key
- A pin code must be inserted (4 digit numbers)

The pin of factory is 0000: *P:0000*, press for confirm.

If the user does not know the pin or to program it for the first time, the user must enter the set up through the switch and access the menu *CHG_PIN*.

Note: The functions availables are the following:

DISPLAY	DESCRIPTION
---------	-------------

<i>CAL-PA</i>	(metrological)
<i>CAL O</i>	(metrological)
<i>CAL</i>	(metrological)
<i>GrAuT</i>	(metrological)
<i>Parame</i>	
<i>CONF:9</i>	
<i>LESL</i>	
<i>AbTUM</i>	
<i>FABr: C</i>	(metrological)

If you don't know the pin code, enter the setup via the switch and access to the CA.PASS menu.

5 Technical menu NO metrologic

Parameters (Parame)

COM1, COM2, RS485

Frame

Baud

Protoc

Adress

Delive

Configuration (Config)

Filter

Date

Time

Sleep (only for LED)

Mv

Language

CH.PASS

I.COUNT

AUTARB

BLight (only for LCD)

5.1 MENU *PARAME*; **COM1, COM2 and RS485**

Once the Pin is introduced in the mode of limited programming, the display is going to show the following message:

<i>PARAME</i>	In the mode of opened programming, it will show <i>CAL---PA</i> , press \downarrow key till it show <i>PARAME</i> . Press \leftarrow for access. With this function you can set NON METRO-LOGICAL parameters. Use \uparrow and \downarrow for select the option and \leftarrow for access.
COM 1	Setting up port 1 Rs 232 to PC, Printer, etc....
COM 2	Setting up port 2 Rs 232 to PC, Printer, ethernet, etc....
RS485	Setting up port 2 on Rs 485 mode. Option only available with RS 485 board.

5.1.1 FRAME

The frame allows data communication format.

The possible choices are:

7/none/2, 7/odd/1, 7/odd/2, 7/even/1, 7/even/2, 8/none/1, 8/none/2, 8/odd/1 y 8/even

5.1.2 BAUD RATE *baud*

It allows the definition of the speed of communication using the cannel of series rs232 com1, com2 and Rs485

The possible choices are:

300, 600, 1200, 2400, 4800, 9600, 19200, 38400, 57600, 115200 baud.

5.1.3 PROTOCOLO *Protocol*

Currently the terminal includes different protocols of communication that can be used through the port of RS-232:

5.1.4 *Ind.Add*

Adjust the direction of the terminal.

<i>SP.2</i>	Protocol – SIPI II -- standar sipi series of the type II (22 characters)
<i>Toledo DS</i>	Protocol – Toledo DS
<i>ERIC</i>	Protocol – ERIC
<i>EPSA</i>	Protocol EPEL
<i>EPEL A</i>	Protocal EPEL A
<i>EPEL 80</i>	Protocal EPEL80
<i>M-L</i>	Protocol of METLER
<i>Mobba3</i>	Protocol Mobba3
<i>F501</i>	Protocol of F501

<i>SAIE</i>	Protocol SAIE
<i>MULTIP</i>	Protocol MULTIPUNTO 2000
<i>Seur</i>	Protocol SEUR
<i>Tisa</i>	Protocol TISA
<i>Ud-O</i>	Protocol VDO
<i>SScar</i>	Protocol SENSOCAR
<i>CScomp</i>	Protocol CAS NOVITUS
<i>Sb-400</i>	Protocol SB-400
<i>SMART</i>	Protocol Smart
<i>TXL</i>	Protocol Teacsul
<i>BILANC</i>	Protocol Bilancai
<i>ALb.</i>	Fiscal memory protocol
<i>GI CONF</i>	Communication protocol with GISCALE
<i>none</i>	Protocol none
<i>Print</i>	Printer protocols
<i>G.Pes</i>	ETD special protocol

5.1.5 *Tr.99r* (MODE OF TRANSMISSION)

It allows the configuration of the terminal to send the information to the PC through one of the following modes:

Continuos: the terminal sends the chain of information, depending on the protocol, in a continuous way only for high requirement applications (1sample each 5ms)

Manual: the terminal sends the chain of information, depending on the protocol, when pressing the key **PRINT** ^{kg} |

pc req.: the terminal sends the chain of information, depending on the protocol, when the order from the PC has been received.

Stable: the terminal sends the chain of information, depending on the protocol, once it has acquired a value of steady weight.

Interval: the terminal sends the chain of information, depending on the protocol, when a variation of the weight is obtained.

Stable 0: the terminal sends the chain of information, depending on the protocol each time takes stability and the value is different to 0. It needs to pass trough 0 each time.

Repeti: on this mode the indicator work as a repeater from another GI400 in mode SIPI II continues or interval. Valid for RS485, for RS232 (limit distance: 16m) or ethernet. When RS232, use the COM2 in both computers.

5.1.6 OPTIONAL RS485

Only works with RS485 board.

Protocols available on RS485 mode with ID are:

MULTIPOINT 2000 AND SENSOCAR WITH INDICATOR CAN BE SET AS A REPEATER.

On indicator with RS485 board board you need to set **PARAME** → **RS485** → **Protocolo SIPI II** → **Trigger contin.**

On indicator with RS485 board wich works as a repeater, you need to set **PARAME** → **RS485** → **Protocolo SIPI II** → **Trigger romte.**

The repeater send of it COM2 (RS232) the SIPI II frame received.

In case you use mode *REPETI* by RS232 (without the additional RS485) config the COM1 the same way like the RS485.

5.2 ETHERNET MENU (IT ONLY WORKS WITH AN OPTIONAL ETHERNET BOARD)

Connect the equipment to the PC using a switch. Enter the IP of the device in the browser **192.168.0.130 (by default)**



Enter the username and password. **(Admin and 1234 by default)**

In the **“Local IP Config”** tab you can change the IP

firmware revision: v3013 ESP

GIROPES
WEIGHING SOLUTIONS

GI ETHERNET

Current Status

Local IP Config

TCP/UDP mode

Misc Config

Reboot

IP config

IP Type:

Static IP: . . .

Submask: . . .

Gateway: . . .

Dns Server: . . .

Help

- **IP type:** StaticIP or DHCP
- **StaticIP** Module's static ip
- **Submask** usually 255.255.255.0
- **Gateway** Usually router's ip address

In the **“TCP / UDP mode”** tab you can change the port.

firmware revision: v3013 ESP

GIROPES
WEIGHING SOLUTIONS

GI ETHERNET

Current Status

Local IP Config

TCP/UDP mode

Misc Config

Reboot

Socket A Parameters

Work Mode: |

Local/Remote Port Number: (1~65535)

PRINT:

ModbusTCP Poll: Poll Timeout: (200~9999) ms

Enable Net Heartbeat Packet:

Registry Type: Location:

Help

- **local port** 1~65535, when TCP Client, set this to 0 means use random local port
- **remote port** 1~65535
- **packet time/length** default 0/0, means automatic packet mechanism; you can modify it as a non-zero value

You can change the username and / or password in the **Misc Config**
If you forget them, you have to open the device and press the RST pads for 5s to reload the factory settings.

5.3 CONFIGURATION MENU

Once the PIN has been introduced, the user is in the mode of restricted programming, move up to **CONFIG**. By using this function the user can program the following NO METROLOGICAL parameters:

<i>FILTER</i>	filters
<i>DATE</i>	date
<i>TIME</i>	hour
<i>SLEEP</i>	autostanby (only for LED version)
<i>mV</i>	mV of the cell
<i>LANG</i>	Languange
<i>CH.PASS</i>	Password change
<i>I.COUNT</i>	Internal accounts
<i>CODES</i>	Name of the item1, item2 and tcode
<i>AULArb</i>	Tare self-locking
<i>BL-shL</i>	(Only for LED version)

FILTER: SELECT BETWEEN 6 PRESETS OF FILTERS CHANGING THE VALUE OF THE FILTER. PREDEFINED VALUE 2.

filter	descripton	Filter value						
		0	1	2	3	4	5	6
d.filte	Display refrechment		1	1	1	1	1	1
Stb	Filter of stability		3	4	5	6	7	8
tmp.stb	Time of stability		2	2	2	2	2	2
Average	Mobile average		7	9	11	13	15	20

DATE: Select the date in the format DD.MM.AA. Being DD the day, MM the month and AA the year.

TIME: Select the time using the format hh.mm.ss. Being hh the time in format 24h, mm the minutes and ss the seconds.

SLEEP: Choose the time of SLEEP. If toFF is in 00, the SLEEP is deactivated. The value introduced is the time without variation due to weight or the time that the device lasts to get into standby from the moment when the key has been pressed. It only works when the excitation comes from the optional battery. This option is incompatible with the additional Ethernet board.(Only for LED devices).

MILIVOLTS: It shows the milivolts of the load cell.

LANGUAGE: : using this menu the user can choose the language in which the tickets are going to be printed and which appears on the display. The languages that are available are: Spanish, French, English, French and Italian.

PASSWORD CHANGE: It changes the entrance password to the technical menu, the user must introduce first the current password and then the new one. The password by default is 0000.

I.COUNT : It shows the data of the converted ALI. in mode CAL.ABI. Press **MR** | **ESC** to exit.

CODES: It allows to edit the name of the item1, item2 and tcode.

AUTARB: Using this menu the user can choose if s/he wants to block the tare automatically.

BACKLIGHT: allows to select backlight working mode within Auto, ON, OFF (only for LCD devices).

5.4 TEST

After entering the PIN in the programming mode, scroll to **LESL**. With this option you can check the correct functioning of the LEDs, or LCD

6. PRINTER

The available printers are the following ones:

- IMP05
- IMP27
- IMP28

The working of the printer is described below:

When the user presses the key **PRINT**^{kg} | the weight is printed, with its number of weighing and its corresponding tare if the mode of transmission is manual (5.1.15).

The user can do successive weights pressing the key **PRINT**^{kg} |. This process can be done if the system goes first to zero or if a tare is done or if an additional weight is situated on the platform.

Once the user has done all the needed weights, when pressing the key **MR** | **ESC** the user will obtain the definitive ticket with the number of weights and the total weight in case that the device has the accumulation option in active mode.

If the accumulation mode is automatic, there should be chosen **tri99r Stble**. Conversely, if the transmission mode is manual should be chosen **manually tri99r**

The printed ticket has 40 characters wide.

6.1 TICKETS FORMATS GI400:

FORMATS FOR WEIGHT

PRNF1

```

Weighing Number: #85

08:33:57      25/11/14

Net:          2.400 kg

Tare:         0.000 kg

-----
    
```

PRNF2

```

Weighing Number: #86

08:37:25      25/11/14

Net:          2.000 kg

Tare:         0.000 kg

Gross:        2.000 kg

-----
    
```

FORMATS COUNTING

PRNF3

```

Weighing Number: #87

08:41:28      25/11/14

Unit W:       222.222229 g

Tare:         0.000 kg

Gross:        2.000 kg

Net:          2.000 kg

Total Units:   9 u

-----
    
```

PRNF4

```

Weighing Number: #88

Unit W:       222.222229 g

Tare:         0.000 kg

Gross:        0.400 kg

Net:          0.400 kg

Total Units:   0 u

-----
    
```

FORMATS CHECKWEIGHER

PRNF5

```

Weighing Number: #89

08:46:13      25/11/14

Target weight: 1.000 kg

Actual weight: 0.400 kg

Deviation:    0.600 kg

-----
    
```

PRNF6

```

Weighing Number: #90

Target weight: 1.000 kg

Actual weight: 2.000 kg

Deviation:    1.000 kg

-----
    
```

TOTALIZATION *PrnF 1 TO PrnF6*

```

=====
                                TOTAL
=====

08:58:33          25/11/14

*****

Weights:#00095 - #00096

Number of Weights:00002

=====

Tot Gross:      4.000 kg

-----

Tot Net:        4.000 kg

-----

Tot Tare:       0.000 kg

=====
    
```

FORMATS FOR ACCUMULATION (MANUAL OR AUTOMATIC) WITH TOTALIZATION

PrnF .7 M.LINE

3 header lines of 40 characters editable with the software
"configuration tool"

```

-----
-----
-----
-----
Fecha:          Hora:          Nr. Ticket
25/11/0014     08:51:06     000091
N.Pesada Código  Tara kg      Neto
kg
 1  041608  0.000 kg  0.400 kg
 2  041608  0.000 kg  0.400 kg
 3  041608  0.000 kg  0.400 kg
Tot. Pesadas          Tot.Peso Neto
kg
      3                      1.200 kg
-----
    
```

PrnF .8

3 header lines of 40 characters editable with the software
"configuration tool"

```





-----
-----
-----
-----
Fecha:25/11/0014          Hora:08:54:42
Prg:001
Nr. Ticket: 000093      Código: 041608
G  2.000 kg
T  0.000 kg
N  2.000 kg
-----
    
```

PrnF.7 S.LINE

```

 1  041608  0.000 kg  0.400 kg
 2  041608  0.000 kg  0.400 kg
 3  041608  0.000 kg  0.400 kg
    
```

7. MESSAGES OF ERROR

DISPLAY	POSSIBLE CAUSES	SOLUTION
 <p>Function of initial zero setting or through a key  in process (blinking message).</p>	<ol style="list-style-type: none"> 1. On the scale there is a weight value superior to the accepted limit of the function. 2. The weight on the scale is not steady. 	<ol style="list-style-type: none"> 1. Unload the scale . 2. Wait until the weight is steady. <p>If the anomaly persists you must ask for help to your supplier service centre.</p>
 <p>OVER LOAD</p> <p>The analog sign of the load cell is out of the working range of the A/D chip. This error finishes when the sign reenters the expected range.</p>	<ol style="list-style-type: none"> 1. Connector of the load cell not connected. 2. Broken cable. 3. Broken load cell (due to overload). 	<ol style="list-style-type: none"> 1. Control that the connector is correctly connected. 2. Control carefully the cable of connection to the load cell and replace it if it defective. 3. Control the sign of the cell when unloading. If it is very high you must also replace it. <p>If the anomaly persists you must ask for help to your supplier service centre.</p>
 <p>UNDER FLOW</p> <p>The analog sign of the load cell is out of the working range of the A/D chip. This error finishes when the sign reenters the expected range.</p>	<ol style="list-style-type: none"> 1. Connector of the load cell not connected. 2. Broken cable. 3. Broken load cell (due to overload). 	<ol style="list-style-type: none"> 1. Control that the connector is correctly connected. 2. Control carefully the cable of connection to the load cell and replace it if it defective. 3. Control the sign of the cell when unloading. If it is very high you must also replace it. <p>If the anomaly persists you must ask for help to your supplier service centre.</p>
 <p>ERROR RD/WR EEPROM</p>	<ol style="list-style-type: none"> 1. Error after an operation of Reading or writing of the EEPROM device 	<p>If the anomaly persists you must ask for help to your supplier service centre.</p>

8. CONNECTIONS

8.1.1 INTERFACE SERIES RS-232 COM1/2

The instrument includes in the standar model a series exit of the type RS232.

DESCRIPTION OF THE CONNECTOR PIN-OUT MALE EXIT SERIES RS232-COM1

N° pin	DESCRIPTION	DIRECTION
2	TX (RS232C - TRANSMITTER)	EXIT
3	RX (RS232C - RECEIVER)	ENTRANCE
5	GND (SIGNAL COMMON)	

8.1.2 INTERFACE SERIE RS-485 COM2

The instrument includes in the standar model a series exit of the type RS485.

DESCRIPTION OF THE CONNECTOR PIN-OUT MALE EXIT SERIES RS485-COM2

N° pin	DESCRIPTION
1	EARTH
8	RTx -
9	RTx +

8.1.3 ADDITIONAL BOARD 4-20mA/ 0-10V ANALOGUE

n° pin	DESCRIPTION
6	GND
7	V _{OUT}
8	I _{OUT} -
9	I _{OUT} +

8.1.4 ADDITIONAL BOARD 4E/4S(relays)

n° pin	DESCRIPTION
1	RLY1_C
14	RLY1_NO
2	RLY2_C
15	RLY2_NO
3	RLY3_C
16	RLY3_NO
4	RLY4_C
17	RLY4_NO
5	+5V _{DC}
18	GND

n° pin	DESCRIPTION
13	IN1-
25	IN1+
12	IN2-
24	IN2+
11	IN3-
23	IN3+
10	IN4-
22	IN4+
9	+5V _{DC}
21	GND

8.2 CONNECTIONS SCHEME IP65

CONNECTIONS SCHEME FOR VISOR GI400 IP65

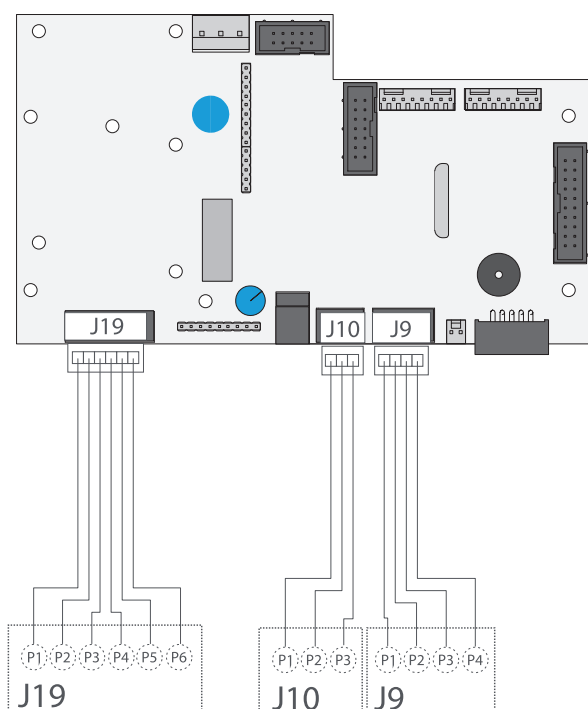

**CABLE DE CÉLULA
CONNECTOR J19**

pin 1	IN+ (out cell)
pin 2	IN- (out cell)
pin 3	SENSE+
pin 4	SENSE-
pin 5	EXC+
pin 6	EXC-

**RS232-1
CONNECTOR J9**

pin 1	-
pin 2	RX
pin 3	TX
pin 4	GND

**RS232-2
CONNECTOR J10**

pin 1	RX
pin 2	TX
pin 3	GND

OPTIONAL SCHEME 4-20mA/0-10V (ANALOGIC)

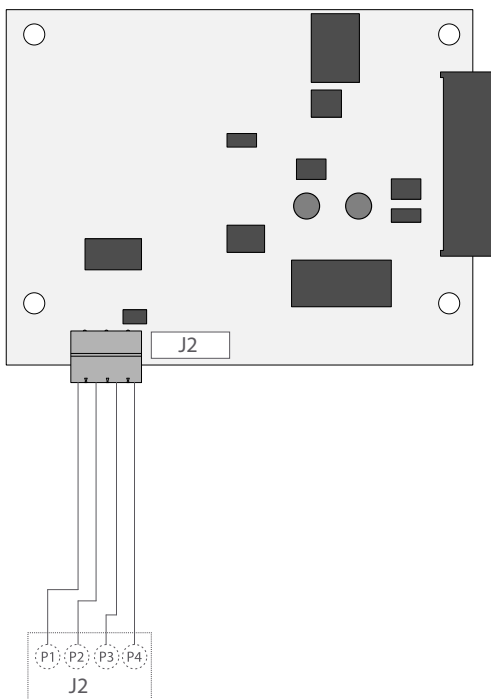

OPTIONAL SCHEME 4E/ES (RELAYS)

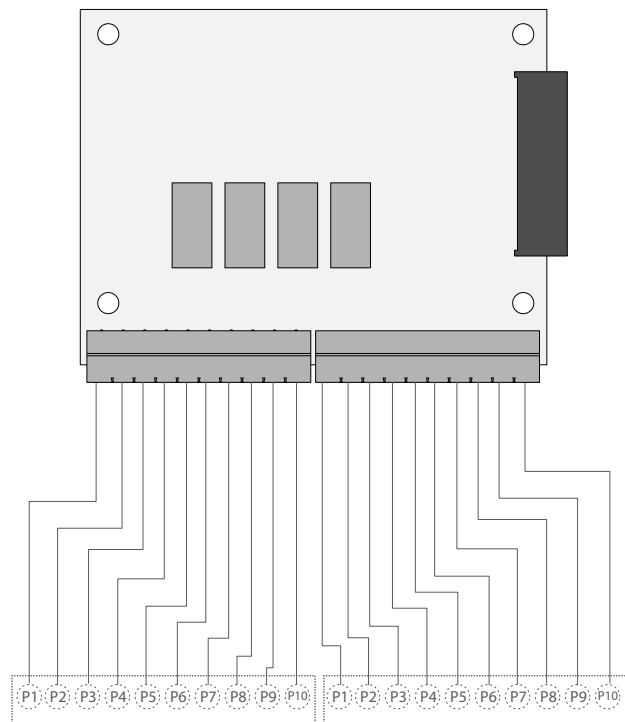

CONNECTOR J2

pin 1	I_{OUT+}
pin 2	I_{OUT-}
pin 3	V_{OUT+}
pin 4	V_{OUT-} (GND)

pin 1	RLY1_C	pin 1	IN1 -
pin 2	RLY1_NO	pin 2	IN1 +
pin 3	RLY2_C	pin 3	IN2 -
pin 4	RLY2_NO	pin 4	IN2 +
pin 5	RLY3_C	pin 5	IN3 -
pin 6	RLY3_NO	pin 6	IN3 +
pin 7	RLY4_C	pin 7	IN4 -
pin 8	RLY4_NO	pin 8	IN34+
pin 9	+ 5V _{DC}	pin 9	+ 5V _{DC}
pin 10	GND	pin 10	GND

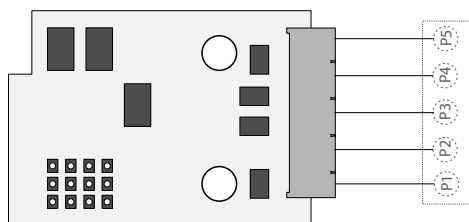
OPTIONAL SCHEME RS485

pin 1	RTX -
pin 2	RTX +
pin 5	EATH

9. DSD MEMORY

It is possible to increase the operation of the weight indicator with the additional plate that performs the function of FISCAL MEMORY; It consisted in filing all the weight values transmitted to a computer for a subsequent processing or integration of the data transmitted by the COM serial channel.

Each archived value is associated with an ID code. The stored value can be consulted in the display of the indicator using the ID. (As control with respect to data printed by the PC).

The fiscal memory can store a maximum of 300 000 weighings, after which, it re-writes on the heavy number 0.

With the serial command "PID" or via the key **PRINT**^{kg}, the scale number, the gross weight, the tare weight and an ID that unequivocally identifies the weighing is sent, only in case the platform is **stable and The gross weight is not negative.**

The ID have the following format:

<Unique code number>, <Number of weight>

Unique code number: 5 digit number ranging from 0 to 300 000, indicative number of complete single code of fiscal memory.

The fiscal memory can store a maximum of 300 000 weights, after which the weighing number starts again by 00000 and the unique code number is incremented one at a time.

The weighing relative to an ID can be verified only if:

Has a unique code number equal to the current one in the fiscal memory and a weighing number less than or equal to the last value received with the "PID2" command.

10. LOAD CELL CONNECTOR

The device is completely supplied for the connection of the transducer (load cell). The kit includes:

- 1 male connector to be welded (9 tracks)
- 1 coverage/blocking cable protected

The cable that comes from the transducer or transducers is connected by welding it to the device. The user must be very careful with its quality and the isolation between the conductors and the use of a good alloy of tin. A bad quality product or a product that is not appropriated could damage or alter the correct working of the device.

In the figure 7 it is indicated the topography of the connector; the pins have the following functions:

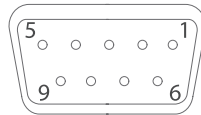

Fig. 8 - Delta connector 9 tracks for the LOAD CELL(S) ENTRANCE

FUNCTION PIN IN C.D.C.					
N° PIN	NOMBRE	FUNCTION	N°PIN	NAME	FUNCTION
1	-EXC	(- EXCITATION)	4	+SENSE	(+ TERMINAL OF CORRECTION)
2	-SENSE	(- TERMINAL OF CORRECTION)	5	+EXC	(+ EXCITATION)
3	GND_A	(ANALOG MASS)	6		NOT CONNECTED
7	-OUT	(- TRANSDUCER SIGN)	9		NOT CONNECTED
8	+OUT	(+ TRANSDUCER SIGN)			

If the transducer includes a connection cable with 4 wires plus protection, and not with 6 wires plus protection, the excitation (+) of the device must be connected with SENSE (+) and the excitation (-) with SENSE (-) joining the pin 1 with the pin 2 and the pin 4 with the pin 5. To reduce the electrical and radio interferences to the minimum, all the connection cables between the device and the transducer must be of a protected type, and all the system must be connected to an optimal earth wire.

The supplying company of the device can supply a type of connection cable that was made on purpose for such conditions. This cable includes a double protection to be welded to the terminals of the shield or on earth.

The following figure shows the different parts involved in the connection of the shields of protection of the cable.

External protection of the cable. It must be pressed in the metal box for cables with terminal moustaches which must be tightened between the two lids of the coverage

Ending of the internal protection of the cable. It must be closed in the metal box for cables of the NB. Protection: Do not connect to the pin 3 of the connector

Coverage protected with conductive material

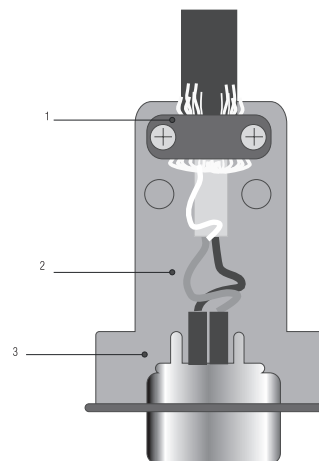

11. REMOVAL OF ELECTRONIC EQUIPMENT



For the European Union customers:

All the products that have arrived to its ending in their life cycle must be restored to their builder so that they can be recycled. For further information about the restoring modalities, please contact your supplier.

12. OPTIONAL BATTERY

The GI400 has three LED battery indications by LEDs.



HIGH battery level (100% - 70%)



MEDIUM battery level (70 % - 40%)



LOW battery level (- 40%). You must connect the equipment to a power outlet.



During the charge (only LCD model)

13. WARRANTY

This viewer is guaranteed against defects in materials or workmanship for a period of 1 year from the date of delivery.

Giropès, will be responsible for repairing the viewer during this period.

This warranty does not cover damage caused by misuse or overloading.

The warranty does not cover shipping costs (freight) necessary to repair the balance.

NOTES:

GIROPES)

Pol. Empordà Internacional Calle F. Parcela 15-16
17469 VILAMALLA - (Girona) SPAIN
T. (34) 972 527 212 - F. (34) 972 527 211